



Bradley Rivers, Brighton University, SoAD: ADM04 Workbook: Re-I-Y the broken cycle.



## CONTENTS:

Page 3: Statement of Intent

Page 4: Introduction

Pages 5-10: Preliminary Context

Pages 11- 25: Case Studies

Pages 26- 31: Alternatives and Suggestions

Pages 32-35: Critical Conclusions

Page 36: Film Bibliography

Find the original PDF on:

[www.BradleyRivers.co.uk/Blog/BrightonWorkBook](http://www.BradleyRivers.co.uk/Blog/BrightonWorkBook)



## STATEMENT OF INTENT

We are built to fix. In the UK among many other 'developed' countries, we are denied or deny ourselves that right and our products are filling landfill sites.

The goal is to live in a circular economy, but consumerism and capitalism both encourage this to fail. Companies want us to keep buying and binning their merchandise. This modern, wasteful way of living fuels global warming and increases our carbon footprints, in the manufacture of more products one could argue we don't really need.

The cycle is broken.  
 We can fix it.  
 We are meant to fix things.

### The 'manifesto' aims to:

- i. Provoke thought into the connection we have with our products and alternatives to problems caused by our throwaway society.
- ii. To raise awareness of the longer lasting issues of E-waste and product disposal.
- iii. Assess the reasons behind our attitudes, how we feel about products, how we treat them and how these needs to (and might) change.

### The workbook aims to:

- i. Clarify the problem at hand: it's causes and potential ramifications.
- ii. Identify cases of what we currently do in the UK, and to a lesser extent abroad, in relation to waste products.
- iii. Critically assess the end-of-life section in the life cycle of products.
- iv. Suggest other (existing) solutions for durable design and reduction in our landfill sites, whilst maintaining the circular economy goal.
- v. Promote an idea of a mobile, communal place where products can be fixed and maintained, to increase our respect/connection with them and each other.

### KEY POINTS:

- 1- "The average power drill is used for somewhere between six and twenty minutes in its entire lifetime, drilling on average 6 holes- let's make things fixable!" Nick Gant, Materiality presentation, Brighton School of Architecture and Design, 21<sup>st</sup> October 2019. Every possible product should be designed so that they can be disassembled by their users.
- 2- Every possible part or component in a product should be modular, legally repairable and replaceable by the customer. If you can't fix it, do you really own it?
- 3- There should be easily accessible and easily located places with parts and people to help disassembly and repair. Recycling and end-of-life should be the very last option.

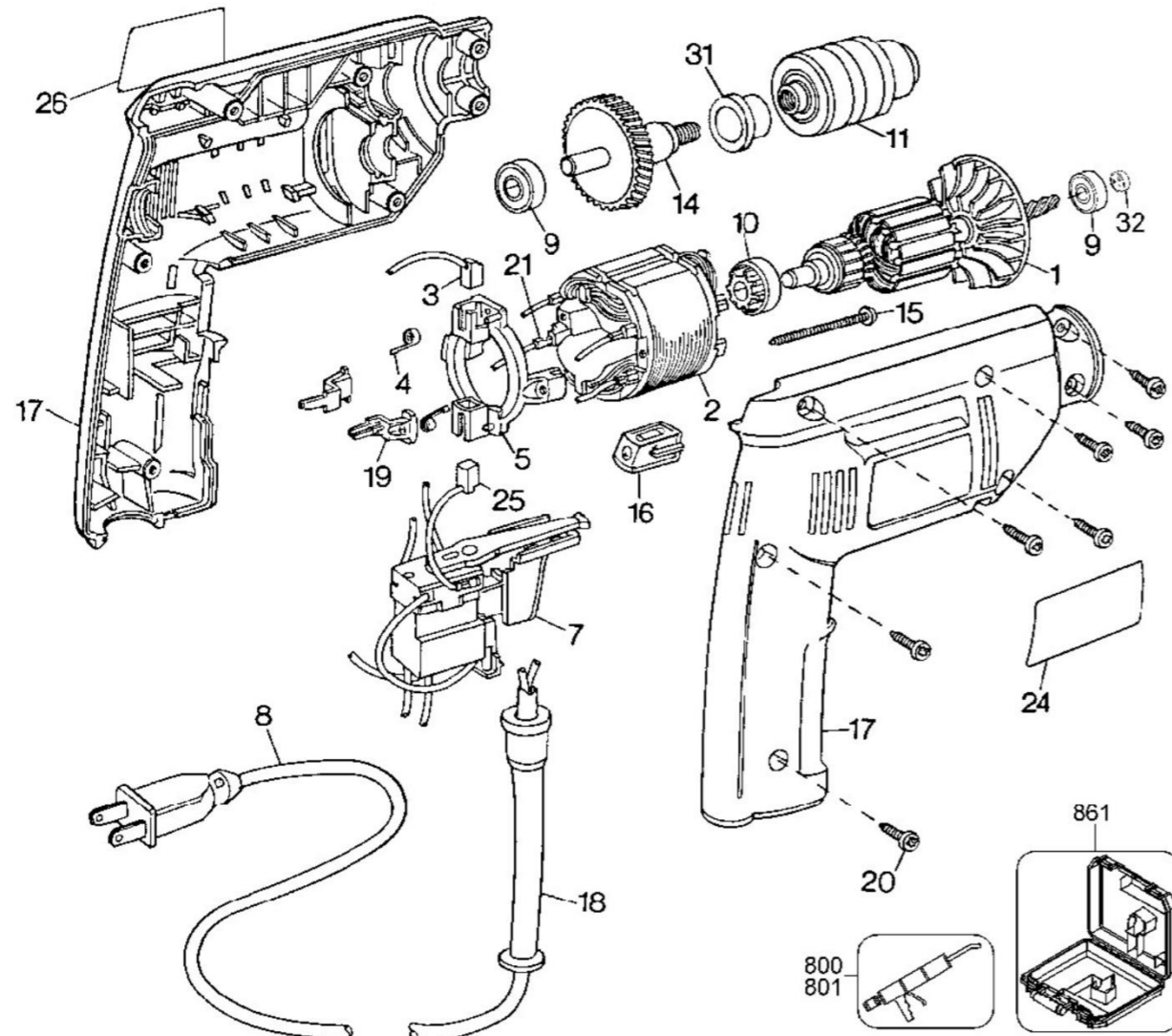

1-Source: <http://www.johngrimwade.com/blog/2017/08/21/taken-apart/>



Some questionable inventions quickly followed times of 50s austerity. If ever products typified a wasteful, throwaway society, the disposable camera, razor and more recently the disposable e-cigarettes would have to be high on the list.



### INTRODUCTION:

It's rubbish, isn't it? We have so much and we throw so much away, thoughtlessly. The main problem with this, as Michael Braungart encapsulates in Cradle to Cradle, is that actually "There is no 'away!'" We must find a way to make our waste into food, fuel and resources.

Fifty years ago no one would dream of throwing a camera away. There are endless stories of prudent parents, but things can change a lot in a generation: it is threatening our current way of life and the futures of others, globally.

Many products may now seem so complicated, most probably think they cannot be fixed. Indeed, a recent survey showed that fewer than 10% of people in the UK do (even try to) fix their broken products [1]. The UK has had to double its domestic waste capacity since 2010 from 6.3 million tonnes to 13.5 million tonnes. Britain is no longer a "make do & mend" society.

Is this a fear of breaking something that is already broken, or a fear of learning how? Is it that broken or waste products are an inconvenience which is too easily over come? Or is it simply that people do not have enough time and it is 'cheaper to chuck' and buy a new one'? A cynic might say it is probably a combination of all the above with a dash of evolved laziness and greed, but there is much more to it than that; we have been impelled.

It is true that certain things were easier to fix, but we previously seemed more inclined to try to fix broken products. Social studies will show that this can be directly linked to wealth: In less affluent and developing countries, (for example Cuba, stunted by the US embargo) people still fix their products, maybe not with the pure intent of saving the environment, but with a mindfulness towards energy and cost. As we strive for a circular economy, products will have to be designed so that they can be dismantled and fixed: Repair should come before recycle.

### KEY POINTS:

- 1- E-waste is defined as anything that needs a plug.
- 2- We've been encouraged to throw away and buy new products for economic reasons so that now, in the UK, we are no longer inclined to try to fix products, which is unsustainable.
- 3- If you want to see how resourceful and practical less privileged people can be (and for some general, occasional perspective) check: [www.gapminder.org/dollar-street/matrix](http://www.gapminder.org/dollar-street/matrix)

Classic cars in Cuba. People continue to keep these cars going, not simply because tourists now like them, but because they had to. When Cuba was under a USA trade embargo, if you didn't fix what you had, you didn't have it. This resolve, combined with other factors, has Cuba still in the top 10 of the Yale environmental performance index 2019.

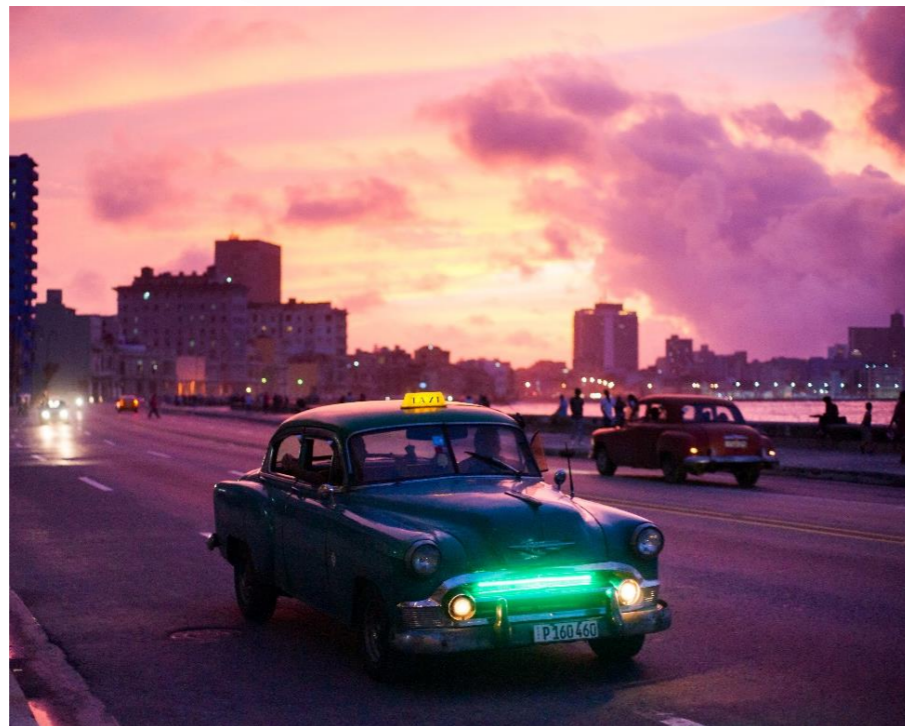

[1] Councillor Clyde Loakes, from the NWLA, was interviewed by Katerina Vittozzi, Sunday 4 November 2018 06:53

Image 1- A Vapourlites disposable e-cigarette, (£4.99) From [www.electrictobacconist.co.uk](http://www.electrictobacconist.co.uk)

Image 2- The FUJIFILM QuickSnap V400 Single Use Camera, (£8.99) image sourced from [www.Currys.co.uk](http://www.Currys.co.uk)

Image 3- Wholesale Cheap Price Shaver Disposable Shaving Razor (£0.06!) Image sourced from [www.Alibaba.com](http://www.Alibaba.com)

Image 4- "Cars in Cuba" sourced from my personal Canva Premium account.



The circular goal:



[www.galvanizing.org.uk/sustainable-construction/life-cycle-analysis/introduction-for-lca/](http://www.galvanizing.org.uk/sustainable-construction/life-cycle-analysis/introduction-for-lca/)

The far more common, broken reality:

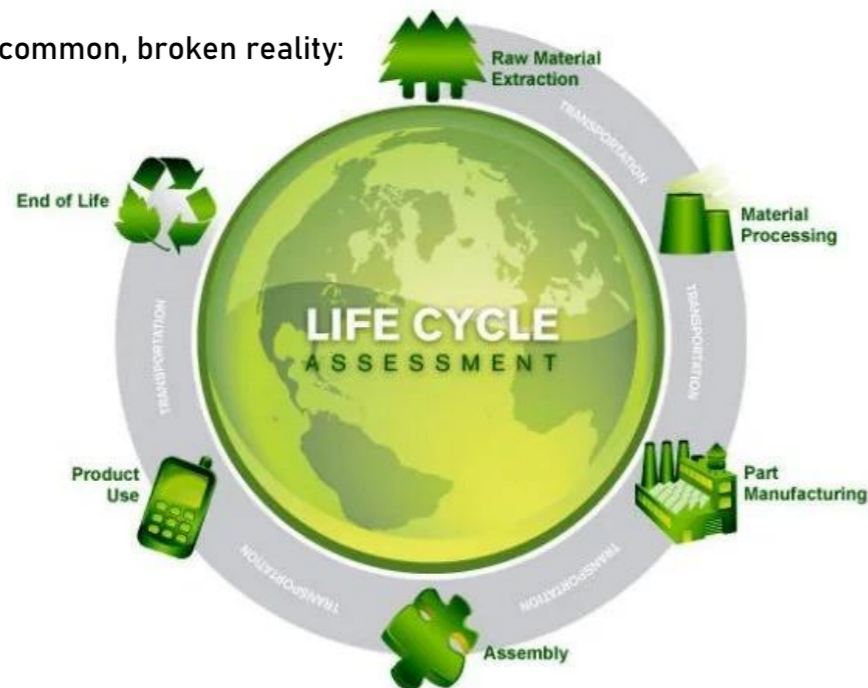

[www.pinterest.co.uk/pin/289497082269192344/](http://www.pinterest.co.uk/pin/289497082269192344/)

### PRELIMINARY CONTEXT: What's the problem?

Gradually people are becoming aware of a key implication of sustaining a lifestyle we have become rapidly accustomed to. We need to make everyday changes to the way we live and we should encourage others too. Our landfills are filling at an unprecedented rate with volumes of materials which are not biodegrading, let alone composting, and cannot be used as biomass. On 15<sup>th</sup> November 2019 it was made public that China's largest landfill site is already full, 25 years ahead of schedule (The Jiangcungou landfill in Shaanxi Province, which is the size of around 100 football fields, was designed to take 2,500 tonnes of rubbish per day but instead receives 10,000 tonnes of waste per day - the most of any landfill site in China) [2] But it is all too common, easy and wrong to just blame China- we in the UK are one of the greatest waste creators and one of the worst recyclers, globally.

The images to the left show an LCA (Life Cycle Assessment), taught widely in the current UK curriculum. In the second image, a crucial arrow is missing: At phase 6 of a product's life all too often broken products never make it anywhere near being raw materials again.

Across the UK, nearly 22 million small items of furniture, more than 11,000 bicycles and over 28 million toys are thrown away each year when they become damaged. Fewer than one in 10 people attempt to repair or restore broken items - despite 42% saying they'd like to learn the skills to do so, according to new research released October 8th 2018 by North London Waste Authority (NLWA). Survey of nationally representative sample of 2,020 UK adults conducted in June 2018 by Censuswide [3]

Some statements and "facts" change so quickly, and usually not for the better, that it becomes difficult to site from published works as the figures worsen. For example, from 2019: 170 million new electrical items are purchased in the UK each year, but we currently recycle less than a third of these when they come to the end of their lifecycle (and we repair even fewer). [4] will be outdated. Why is this? Perhaps it simply comes down to the classics: time and money. We (believe we) do not have enough time to fix a product but we do have enough money to replace it because mass production in developing countries has made purchasing new products online proportionately so cheap and they are quickly delivered to our doors.

[2] <https://www.bbc.co.uk/news/world-asia-50429119>

[3] NLWA North London Waste Authority. Accessed November 10, 2019. "wise up to waste" <http://wiseuptowaste.org.uk/news/22-million-damaged-furniture-items-and-11-000-bust-bicycles-thrown-away-each-year/>

[4] Electrical Safety first; "recycling electrical items. Accessed November 10, 2019. <https://www.electricalsafetyfirst.org.uk/guidance/safety-around-the-home/recycling-electrical-items/>



Viridor Transforming waste™



### PRELIMINARY CONTEXT: A local problem?

There are several possible reasons why we are so ready to throw our stuff away. Trying to fully understand varied human mindsets is a task more for psychological and sociological research but perhaps, for some people, it is simply too easy to chuck it. Some products fit into a bin bag so easily, they are then out of sight, out of mind, and we like easy solutions. If a computer program goes wrong, we are far more likely to uninstall it and try again. In good, modern designs, the hardware needs to be as flexible and user-friendly as the software.

We are all probably aware that most products available to us are designed to fail. This built in obsolescence fuels our economy, filling pockets but also filling our waste sites. Waste electrical and electronic equipment (e-waste) are key contributors (6 million electrical items are thrown away each year) but it is in the minutiae where volumes also amount.

Our wanton wastefulness is hardly confined to the world of electronics. Changeworks estimates that 2 million toner cartridges and 30 million inkjet cartridges alone are dumped each year in the UK [5]. Pen running dry? Bin it. Glue stick empty? Bin it. Headphones stopped working? Phone? Laptop? TV remote? The TV itself? You will see them all at your local tip and, more recently and more frustratingly, you can see them tipped in country lanes and rivers in Kent (they are my photos, opposite), which is of course not an isolated issue in the UK.



Another key reason behind why too many people are so 'pro throw' is because of mass production. Products are so cheap now, it is seen by many as cost effective to simply replace than repair, even if a product is recyclable. Attwood, Lambert and Neal explain the situation well in "Product Design in Context":

"... the changes brought about by developments in technology have resulted in far-reaching consequences.... Industrialisation led to changes in production and infrastructure. Many new fields of design were needed to accommodate this and the professional designer came into being. Population explosions occurred in towns and cities where production was centred and a new urban way of life was created. More people needed more products and mass production responded to this need". [6]

Some countries are starting and some are still having their industrial revolution, although it seems few lessons have been learned from the errors the so called 'developed West' has been making. Still, the Economy comes first and the Eco bit is forgotten or put to one side.

[5] [www.changeworks.org.uk/](http://www.changeworks.org.uk/)

[6] Attwood, John/ Lambert, Barry/Neal, Peter, *Design in Context, Product Design*. London/Essex: Pearson, 2008



2- Images on this page sourced from: *The global e-waste monitor – 2014*

### PRELIMINARY CONTEXT: A global problem?

The United Nations says that the UK is the second highest producer of e-waste per capita.

“E-waste is one of the fastest-growing challenges in both developed and developing countries. Rapid technology innovation and ever-shortening product lifespans are among the factors contributing to the growing amount of e-waste. Over the past two decades, policymakers, producers and recyclers in various countries process it in professional treatment facilities. Unfortunately, despite these efforts, the collection and state-of-the-art treatment of e-waste is limited, and most nations are still without such e-waste management systems. There is a large portion of e-waste (only around 20 per cent of global e-waste is recycled each year, despite 66 per cent of the world's population being covered by e-waste legislation) that is not being collected and treated in an environmentally-sound manner (40 million tonnes of e-waste is either placed in landfill, burned or illegally traded and treated in a sub-standard way)... These “backyard” techniques pose dangers to poorly protected workers and the local natural environment. Global trading of electronics and substandard recycling in developing countries has led to environmental catastrophes in places like Guiyu, China and Agbogbloshie, Ghana, to name two examples”.[7]

Material	Kilo tonnage	Millions of Euros
Iron/Steel	16,500	9000
Copper	1900	10600
Aluminium	220	3200
Gold	0.3	10400
Silver	1.0	580
Palladium	0.1	1800
Plastics (PP, ABS, PVC, PS)	8600	12300
	<b>TOTAL (estimated)</b>	<b>48,000,000,000 Euros</b>

“... up to 60 elements from the periodic table can be found in complex electronics, and many of them are recoverable, though it is not always economic to do so presently. From the resource perspective, e-waste is a potential “urban mine” that could provide a great amount of secondary resources for remanufacture, refurbishment and recycling. For instance, the gold content from e-waste in 2014 is roughly 300 tonnes, which represents 11 per cent of the global gold production from mines in 2013 (2770 tonnes)” [8]

[7] Kazuhiko Takemoto, Director, United Nations University Institute for the Advanced Study of Sustainability, (UNU-IAS)

[8] Baldé, C.P., Wang, F., Kuehr, R., Huisman, J. (2015), *The global e-waste monitor – 2014*, United Nations University, IAS – SCYCLE, Bonn, Germany, (citing the USGS 2014).



3- A palladium mine dug by Sibanye Stillwater. Image sourced from: <https://www.greatmining.com/palladium.html>

### PRELIMINARY CONTEXT: Why?

According to the Environmental Protection Agency in 2014:

“Only 12.5 percent of e-waste (electric or electronic waste) is repaired or recycled. Based on e-waste disposal rates, Americans alone throw out phones containing over \$60 million in gold and/or silver every year. Recycling circuit boards can be more valuable than mining for ore. One ton of circuit boards is estimated to contain 40 to 800 times more gold than one metric ton of ore. There is 30 to 40 times more copper in a ton of circuit boards that can be mined from one metric ton of ore”.

(The trouble is, getting to the bit which contain the materials, such as palladium, that we are so ready to rip open the earth for- see image of a mine, opposite).

“Approximately 350,000 mobile phones are disposed of globally each day, according to 2010 figures from the EPA. That equates to more than 152 million phones thrown away in one year. There are more mobile phones in existence than there are number of people living on Earth. Based on the number of active SIM cards in use, there are more than 7.2 billion mobile devices being used, while there are less than 7.2 billion people on the planet. The growth rate of mobile devices compared to the population growth rate is five times greater” [9]

The same year, the UN University estimated that global e-waste volumes could increase by as much as 33 percent between 2013 and 2017 [10]

Now, in 2019, we are in a bit of a pickle, which has inspired this piece of research and range of suggestions. We love(d) having these products, how much easier they made our lives and the time they saved! We have not planned well for the next step; when these products break.

#### KEY POINTS:

- 1- Phones are seen as disposable commodities.
- 2- This is a global problem and there is a correlation between the GDP of a country and the volume of waste it produces.
- 3- Recycling rarer metals could be a key part of a circular economy, but we need to be able to get the parts containing them out of the products.

[9] <https://earth911.com/eco-tech-20-E-Waste-Facts>, Kimberly Button February 24, 2016, accessed 2<sup>nd</sup> November 2019

[10] Garlapati, Vijay Kumar. "E-waste in India and developed countries: Management, recycling, business and biotechnological initiatives." *Renewable and Sustainable Energy Reviews* 54 (2016)

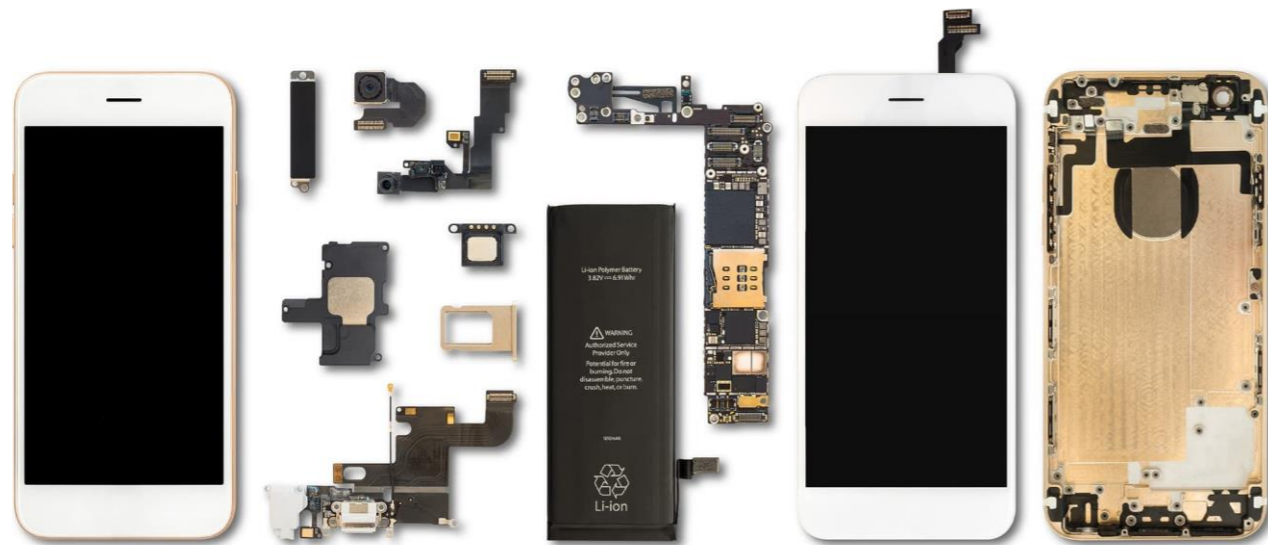

4- A modern, modular phone designed to break down into 11 components. Image sourced from <https://www.ellenmacarthurfoundation.org/explore/circular-design>





[www.agencyofdesign.co.uk/projects/](http://www.agencyofdesign.co.uk/projects/)



5- Old junk? Image sourced from personal, premium Canva account

## PRELIMINARY CONTEXT: Why?

Understanding why we have become so wasteful is a thesis-worthy topic in itself. Researching has unearthed some fascinating arguments. Below is a provocative, germane example between Francisco Martínez and Thomas Hylland Eriksen & Elisabeth Schober:

“... Discarding is an increasingly charged act, a means through which people articulate both an ethics of care and moralities of practice. Any anthropology of waste must be seen as an anthropology of value, as convincingly argued in Thompson’s *Rubbish theory* (1979) [11], which shows how transient objects may, under certain circumstances, become durable and worthy of preservation. In a discussion of speed, architecture and obsolescence, there is an argument that a ‘powerful source of contemporary cultural amnesia [...] has to do with the nature and the life history of the material objects with which people are customarily surrounded’ adding that today ‘it is we who observe the birth and death of objects, whereas in all previous civilisations it was the object and the monument that survived the generations’ [12].

“There is a powerful cultural critique implicit in studying routine obsolescence, rapid disposal and the loss of collective memory from the perspective of the anthropology of waste and value. If rubbish is saved from oblivion and the dump by being turned into durable, timeless goods – i.e. classic cars – then just a short step ahead brings us to a second possibility for a cultural critique based on an anthropology of waste, namely that of eternal recycling rather than maintenance. Decisions ‘to abandon or rehabilitate are always informed by value judgements, not simply by the cost of time, money or effort required’. However, a complementary perspective to this that takes a longer term and/or larger scale as its frame of reference would insist on neither abandonment nor rehabilitation, but constant re-use and recycling, where nothing is ultimately defined as waste, since everything can be returned to a usable, valuable state, like the fermented excrements in which the tastiest tomatoes can be grown. ‘Rubbish does not exist, only resources gone astray’. The anthropology of waste can speak truth to power by seeing anthropological theorising of waste and value theory as a whole, interrogating the transformation of time and space through policies and politics of waste and value, and using the waste/value nexus to challenge the destructive presentism of global capitalism, in such a way positing an ecological model for the economy rather than a predatory one”. [13]

[11] Thompson, M. 1979. *Rubbish theory: the creation and destruction of value*. Oxford: Oxford University Press.

[12] Connerton, P. 2009. *How modernity forgets*. Cambridge: Cambridge University Press.

[13] Thomas Hylland Eriksen and Elisabeth Schober, *European Association of Social Anthropologists in a 2017 response to Francisco Martínez*



[www.oldest.org/technology/light-bulbs/](http://www.oldest.org/technology/light-bulbs/)

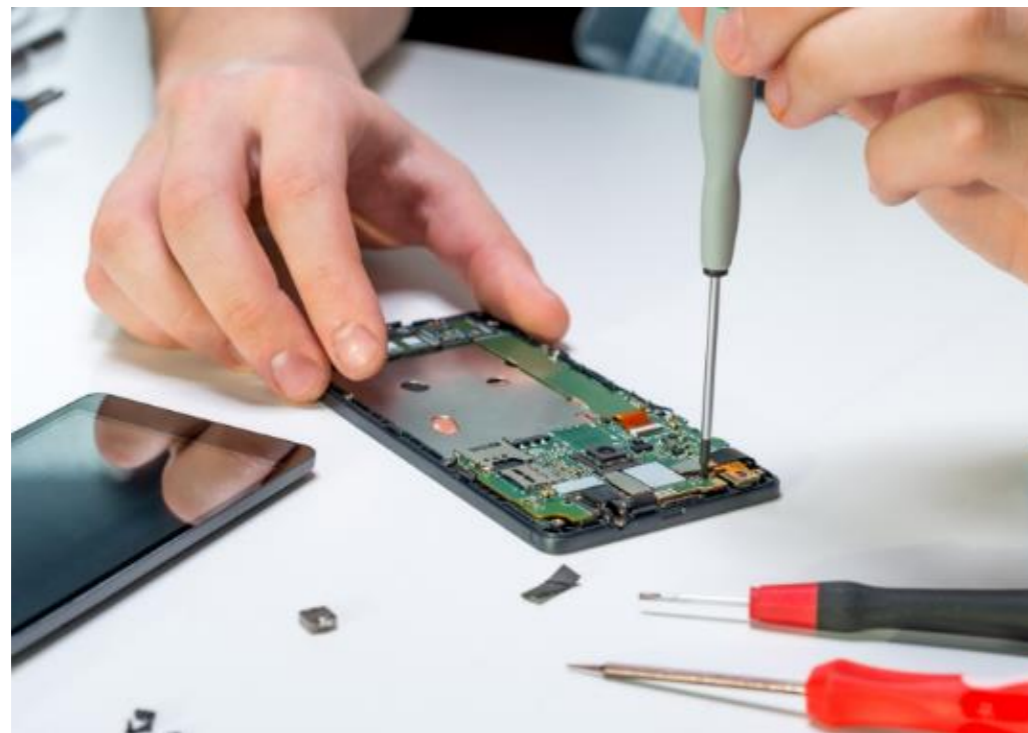

*Phixing fone- Image source: Canva Premium Account*

## PRELIMINARY CONTEXT: Why?

Fascinating though they are, this research is not focussing on the huge issues of human psychologies, recyclability and its conservable ramifications, but instead, hopefully, more proactively on the products, so... What happens when a product breaks, we don't how to fix it, and it won't fit in the bin? Governmental guidelines are that we should "keep waste to a minimum by doing everything you reasonably can to prevent, reuse, recycle or recover waste (in that order)... sort and store waste safely and securely" [14] but this is rarely the reality. People's respect for products and their approach to recycling is rapidly diminishing to levels comparable to their inclination towards repairing.

- 1) They might first check for a usually very well considered warranty on the device or product, to see if it can be replaced or fixed for free.
- 2) Hopefully most people will at least have a look online for a video of how a product can be fixed, but in truth very few can be, without specific tools (3), as is the nature of planned obsolescence. Take, for example, the classic example of the light bulb: Designed to fail. Filaments should burn in inert gases endlessly. Image 2 shows a 118-year-old lightbulb, but there is much less money to be made in making a product last this long. Greater quality would result in greater longevity but that would also mean greater cost, and that's where demand (people) would look at other suppliers.
- 3) The person may look into taking the broken product to a professional who can fix it but they are usually independent businesses focussing on one type of product, potentially based far away and to get to them with one broken product might not be cost effective, especially if the product is older.
- 4) A responsible person might take their broken product to the tip, or save up until they have a car full of products. Tips are essential but also very busy places nowadays, especially at weekends and many will charge you to use them if you cannot prove on site that yours is the correct postcode. You must also not walk there or take too large a vehicle. They reserve the right to reject certain products and if you have too much, they will send you to a commercial waste disposal company (who can be booked through most local councils to collect waste), who will charge, even if you have already paid taxes for larger items to be collected.
- 5) Disgustingly, a growing number of Britons fly tip their waste. Clearly the fines or deterrents are not high enough for this, currently.

### KEY POINTS:

- 1- Use screws/bolts whenever possible and avoid rivets and glues
- 2- Do not make good, green practice so reliant on the customer's choice- make it mandatory further up.
- 3- Cheap doesn't have to be rubbish and rubbish doesn't have to be cheap.

[14] <https://www.gov.uk/managing-your-waste-an-overview> (accessed 10<sup>th</sup> November 2019)



6- All un-cited images on this page are courtesy of my personal Canva Premium account.



7- <https://www.bgr.in/news/heres-why-apple-is-killing-the-3-5mm-audio-jack>



Technology becomes outdated and it makes sense to leave it behind, but this generates a lot of waste (and it can come back in to fashion!)



8- Basis protectionism: Torxx Star head screw from [instructables.com/id/Removing-Security-Torxx-Star-Screw/](https://www.instructables.com/id/Removing-Security-Torxx-Star-Screw/). Specifically designed to make replace/repair harder

### CASE STUDY 1: Rotten apples?

We *can* fix it. Surely, in most cases it is better for us and the environment if we at least try and fix it ourselves, but of course many companies do not actually want you to do that. Indeed, in June 2019 Apple tried to sue an independent Norwegian repair shop for not having the right certification and wrongly branded hardware. Apple lost, and there has been some fallout:

“Since these were phone screens and the Apple logo was only printed on the inside, it would not be visible to consumers. The court thus viewed it as not infringing on Apple's trademark.... Although this victory is a good sign for consumers, the legal details of the case only apply in Norway. In the United States, Apple has been heavily lobbying against Right to Repair legislation”. [15] This case is rumbling right now (2/12/19) shows no sign of abating.

Apple are masters of greed for repeat custom and proprietary, for example you could argue there was no need to change the ubiquitous 3mm jack port for aux and headphones, but they recently did (6). Why? Just for faster USB transfer rates or so customers would buy more? It's not just Apple, of course, but with an estimated net worth of \$1.165 trillion, perhaps it could be suggested that they, along with hundreds of other fabulously wealthy companies could be doing more to consider the environmental implications their designs and products are having.

Practical skills are dwindling and repair jobs are seen as fitting for a different class of people, or ideally machines. It appears your average British person does not have the time, inclination or skills to fix as we used to, but it is not all their fault- companies design their products to be deliberately hard or impossible to fix, for example by using Torxx screws (7). This is an example of classic protectionism and you will know it is rife if you have ever tried to fix a product- they can be comparable to coming up against glues and rivets!

Of course, sometimes things should not be fixed. They are beyond repair or outdated to the point where it makes no sense and would be worse for the environment to keep them going or bring them back. Only then, one could argue, should they be taken to our choice of waste disposal, like a tip or junkyard, where that can meet the eco-friendliest end of life. However, this research suggests that this should be a last resort, and we would do well to have more opportunities and encouragement to fix. Don't (just) recycle- repair, repurpose, reuse!

#### KEY POINTS:

- 1- The United Nations lists the UK as the second highest producer of e-waste per capita: predictable with our kind of economy and condemnable for the same reason.
- 2- We can't keep living like mindless yeast, intoxicating the environment around us.
- 3- Would you boycott Apple? Could you? Are they too far ahead of the competition now?

[15] Wiens, Kyle, and Gay Gordon-Byrne. "The fight to fix it." *IEEE Spectrum* 54, no. 11 (2017): 24-29.



9- Overview of alternative joining techniques in electronic devices for (from left-to-right) a display assembly in an iPad joined to the body using snap fits, LCD screen in a Motorola phone is disassembled using snap fits, memory chips clicked into the motherboard of a desktop computer, CPU clicked onto the motherboard of an HP computer, non-integrated battery in a Motorola phone and a camera clicked onto a motherboard in a mobile phone (source: Floras CEIP report *Designing for a Circular Economy*, iFixit & HP)

Very recently (27<sup>th</sup> November 2019) Apple raised some eyebrows when it told US Congress that the cost of providing repair services is greater than the money the company makes off of repairs.

Apple responded to a series of questions that the US House Judiciary Committee sent to it back in September as part of a broader antitrust probe. In addition to addressing questions about App Store policies and the company's data collection practices, Apple also answered a series of questions about its hardware repair programs. It emphasized that it doesn't restrict repairs or refuse to repair gadgets that might have been fixed previously by unauthorized technicians.

For right-to-repair advocates, Apple's answers weren't good enough. Proponents of a more open source approach to repairing gadgets say that Apple's on-the-record responses are examples of "expert question-dodging" and, in some cases, are "downright false." Apple's responses have even raised questions about the definition of a "repair". That's according to iFixit, a business built on DIY electronics repairs and one of the more consistently vocal groups in the world of product repairs and sustainability. (iFixit cofounder and CEO Kyle Wiens has written opinion columns on this topic, see later pages). Now the right-to-repair arm of the US Public Interest Research Group is also weighing in, saying Apple is trying to "weave around key criticisms." The group is lobbying for Congress to take a harder look at Apple's claims. [16]

"The fact is that Apple, and many other manufacturers, take all manner of actions that restrict repair, which result in higher costs for consumers and a faster rate of obsolescence," says Nathan Proctor, director of the US PIRG's Right to Repair campaign. Proctor also argues that when Apple offers replacement products instead of repairing a device, it is effectively refusing to repair.

Apple did not respond to a request for comment about its definition of repairs.

Lobbyists on behalf of the tech makers have said that letting consumers and unauthorized repair shops fix gadgets could void warranties and lead to serious hazards or allow hackers to exploit insecure products. But proponents of open repairs say that companies like Apple and Microsoft effectively have a monopoly on repair processes and that consumers should have access to the same parts and tools—both hardware and software—required to fix their own electronics.

In other words, a customer might go into the Apple Store or other authorized repair shop for a fix, and the repair might be so complex that the product is effectively replaced. The topic of "repairs" not only becomes one of semantics but also raises the question of whether Apple (and other electronics makers) could be slotting full replacement devices into a definition of repairs. Proctor, of US PIRG, says in his blog post that this is Apple attempting to "create a new category of repair."

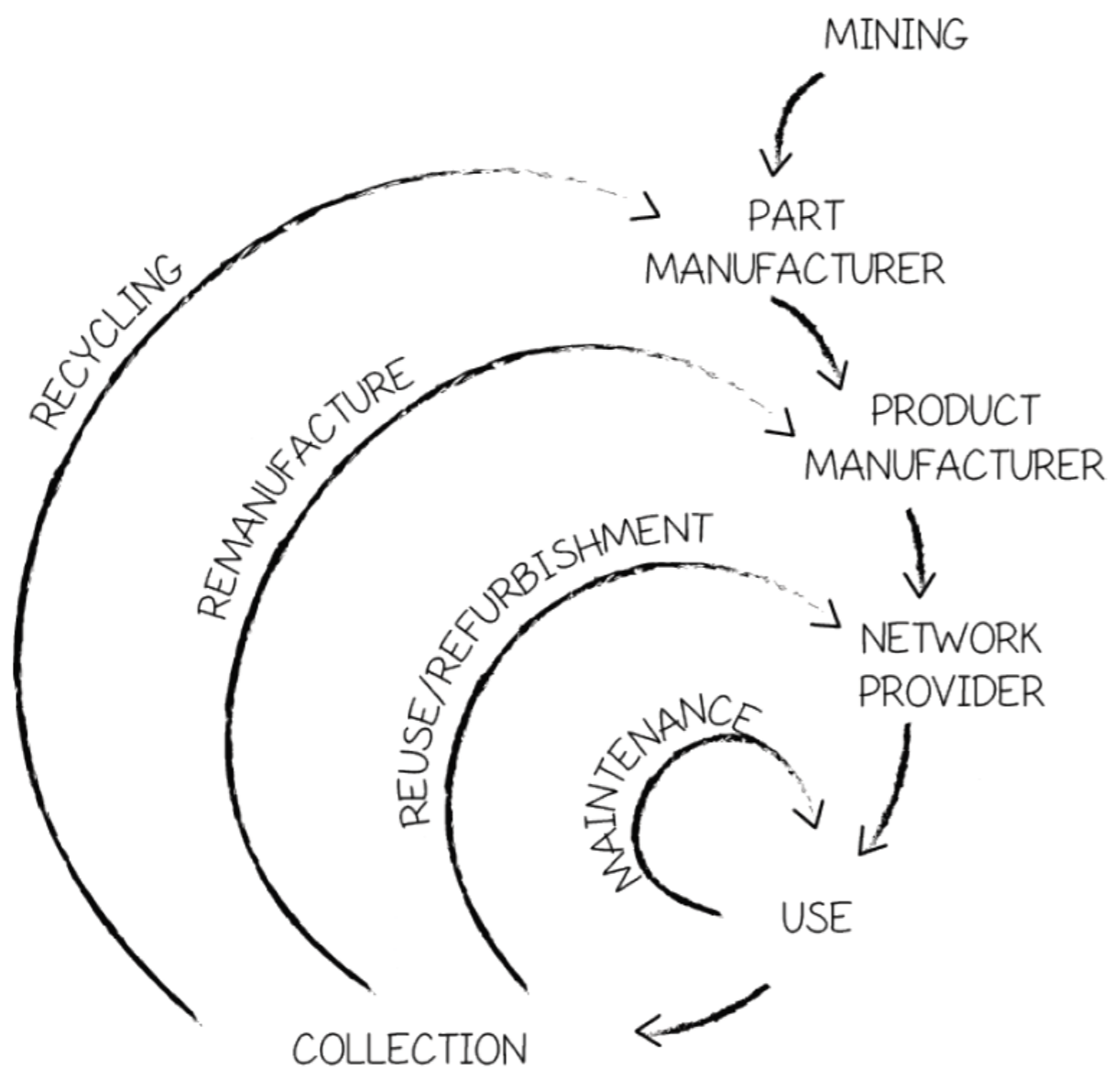

10- The desired circular mobile device model, a suggested systematic approach, expounded by the TU Delft repository for the graduation thesis: Sourced from the Department for International Development and Research for Development, "Working Paper Series: Economic Growth." 2008 (accessed 29<sup>th</sup> November 2019)

Kevin Purdy, a writer for iFixit states that some of the repairs Apple performs are "disingenuous." He says there are instances when a repair to a solid-state drive or a Touch ID sensor on a Mac laptop will result in the replacement of the motherboard, which he likens to "prescribing a heart transplant for a common flu." "Only Apple can, with a straight face, claim that they offer 'repair services through refunds or replacements' on some devices," Purdy writes.

Apple's inability to fix certain modular parts could as much about its design decisions as its repair policies. "If any single part fails, it shouldn't result in a replacement. But they've designed themselves into a corner," iFixit's Wiens says, referring to Apple's attention to sleek, thin products, which may be aesthetically pleasing but equate to hard-to-access glued parts, whether that's in a laptop or an AirPods.

Wiens points to Microsoft's new Surface 3 as an example of what electronics makers could be doing: Previously, if you wanted to swap out a Surface battery you had to replace the whole thing, but now the laptops are easier to disassemble and reassemble. "The engineering triangle is always cost, quality, price," says David Lakatos, the chief product officer for Boston-based 3D printing company Formlabs (See Fablabs and Fab cities later). "In this case it's difficult to draw the line between a company protecting itself from the market of used devices and lost profit, and on the other side, how much more expensive a product would be if they didn't use the type of design or type of glue that optimizes for a single shell, that has some non-reversible elements to it."

Apple's definitions of "repair," "same unit repair," and "replacement" might be an ancillary part of the overall right-to-repair argument between tech makers and repair advocates. (This is covered in different angles in the Right to Repair section later). But it's this kind of verbiage that Wiens calls a "key part of the arguments," because Apple saying certain products can't be repaired (and that they instead must be replaced at a higher cost) is partly what drives consumers to seek out other options at non-Apple repair shops. Consumers might even consider fixing products themselves, which would be easier if they had access to the right parts and manuals—which is the foundation of the whole right-to-repair movement in the first place [16]

- KEY POINTS:
- 1- Though this is a US based article by Goode, such protectionism relates to the UK too.
  - 2- Apple are of course not the only company up to these schemes. Can we break away?

[16] Lauren Goode blogged on 27<sup>th</sup> November 2019 at 11:01 AM for Wired: [https://www-wired-com.cdn.ampproject.org/v/s/www.wired.com/story/right-to-repair-apple-answers-congress/amp?usqp=mq331AQCKAE%3D&amp\\_js\\_v=0.1#referrer=https%3A%2F%2Fwww.google.com&amp\\_tf=From%20%251%24s&ampshare=https%3A%2F%2Fwww.wired.com%2Fstory%2Fright-to-repair-apple-answers-congress%2F](https://www-wired-com.cdn.ampproject.org/v/s/www.wired.com/story/right-to-repair-apple-answers-congress/amp?usqp=mq331AQCKAE%3D&amp_js_v=0.1#referrer=https%3A%2F%2Fwww.google.com&amp_tf=From%20%251%24s&ampshare=https%3A%2F%2Fwww.wired.com%2Fstory%2Fright-to-repair-apple-answers-congress%2F) (accessed 29<sup>th</sup> November 2019)



4- a broken bowl fixed with gold: <https://caloosabelle.com/wp-content/uploads/2018/06/cb-6-14-wabsabi.jpg> By Geoffrey Ionescu



11- A modular, adaptable, easily adjustable and repairable OpenDesk Kit, image sourced from: <https://www.opendesk.cc/open-making>



5- A typical iFixIt kit, from: <https://www.accu.co.uk/en/ifixit-drive-bit-sets> (£59.99)

## CASE STUDY 2: Back to the future

In Japanese culture there is a philosophy of Wabi-sabi, where there is a celebration of the “beauty of things imperfect, impermanent and incomplete” [17] Value is added in the fixing of a product, so much so that some fixings are made with gold (4).

For taking on an Eastern cultural shift, a Western attitudinal shift needs to occur. These issues were not rife 50 years ago, but mass production and consumerism have given rise to a ‘disposal first mindset’, which must be addressed. There are sites: [www.iFixIt.com](http://www.iFixIt.com) (Previously mentioned) and [www.Instructables.com](http://www.Instructables.com): “Making things makes people happy” states instructables.com “one of the friendliest online communities anywhere”. Both actively encourage the kinaesthetic or amateur fixer by providing instruction, tools and kits (5).

But... What if we could open source our products, part by part? (Preferably from near to us, for the carbon conscious). To a great extent, this concept already exists and frontrunners Open Desk (<https://www.opendesk.cc/open-making/our-model>) specialise in furniture products which are assembled by/for the purchaser; a bit like the Ikea enterprise, but flipped. Their angle is that they are “Building a new model of open making”, offering customers the chance to enter the ‘global workshop’, not using an international shop or website but by ‘networking buyers with makers in the local area’. Not only are you put in touch with places to buy locally, which immediately reduces the carbon footprint of the product, but you then also know where your product can be fixed (this has ‘Fab city’ connotations, which are touched upon in more detail later in this research). It keeps the products local, it keeps the products reasonable, it keeps the products fixable and most of all it keeps the products out of landfill. Sadly, Open Desk are not (allowed to be) involved with electronics, merely furniture items. There should be an electronic equivalent in the UK, because:

E-waste is one of the fastest growing waste streams in the world in terms of volume and its environmental impact on the planet. The total amount of e-waste produced has reached approximately 41 million tonnes in 2014 and increasing at a rate of 3–5% every year. A correlation between e-waste generated, gross domestic product and population of the country has also been explored that suggested that the GDP of any country has a direct correlation with the amount of e-waste produced by that country. The population of the country doesn't have a significant impact [18]

[17] Koren, Leonard. *Wabi-sabi for artists, designers, poets & philosophers*. Imperfect Publishing, 2008.

[18] Holgersson, Stellan, Britt-Marie Steenari, Max Björkman, and Klas Cullbrand. “Analysis of the metal content of small-size Waste Electric and Electronic Equipment (WEEE) printed circuit boards—Part 1:” *Resources, Conservation and Recycling* 133 (2018): 300–308.



Kettle being dismantled by a vacuum. Images courtesy of Agency of Design



12- Toaster with exploding fittings courtesy of Agency of Design

### CASE STUDY 3: Design for Disassembly

Plastics are wonderful materials, but we need to stop using them with such disregard for the future. This isn't a research piece on recyclability, but more reuse and specifically repair. Products would be easier to repair if they were easier to dismantle.

Design for Disassembly (DfD) is a movement on the rise: "More and more products are being designed to be dismantled. Plugs are a classic excellent example of this. It is known that the fuse is the most likely component to fail, so even though it could be miniaturised, it is kept easy to disassemble and replaced using only basic normal tools". [19]

Opposite are screen shots from a video of an experiment performed by the Agency of Design, used to show how products could be dismantled for recycling or repair automatically and easily by machine, instead of by hand. Heated vacuums are used to break apart products into smaller, recyclable or repairable parts, which would of course, due to the random scattering, need to be reassembled by hand. They also postulate a retro fitting with their 'exploding plug' concept (image 12) which is what facilitates the kettle and toaster's rapid, automatic disassembly. New products could be fitted with these. However, wouldn't it also be wonderful if old products susceptible to failure could be retro fitted with these as well?

Also on the excellent Agency of Design website is a concept for a modular toaster, with parts that can be posted individually for fixing and a cast aluminium 'life time' toaster, which displays each and every time it is used and records it with the toast. The goal of this is to convey the emotional connection we could and should have with our products. We should want to get them fixed as opposed to replaced. An emotional connection with our products seems a forgotten phenomenon to most, but it would help us think about keeping them "alive".s

Back in Brighton, on the 21<sup>st</sup> October 2019: Ben Bosence explained how: "80% of a products environmental impact is decided at the design stage". Three days later James Tooze explained his research exposing our abundance of excess: "only 1% of materials used to make a product are still in use 6 months after it has been purchased, on average. Disposability is ingrained in our culture and the shift to sustainability has so much cultural friction".

#### KEY POINTS:

- 1- Will ubiquitous methods of disassembly such as thermo-plugs/vacuums catch on?
- 2- Could we retro fit products with generic nuts/ bolts over bespoke fittings and rivets?
- 3- Fines for waste are on the rise, which is good, but companies should be rewarded more for good, empathetic design. Talking of fines and taxes is too simplistic.

[19] Agency of Design [www.AgencyOfDesign.co.uk/](http://www.AgencyOfDesign.co.uk/) (accessed 6<sup>th</sup> November, 2019)

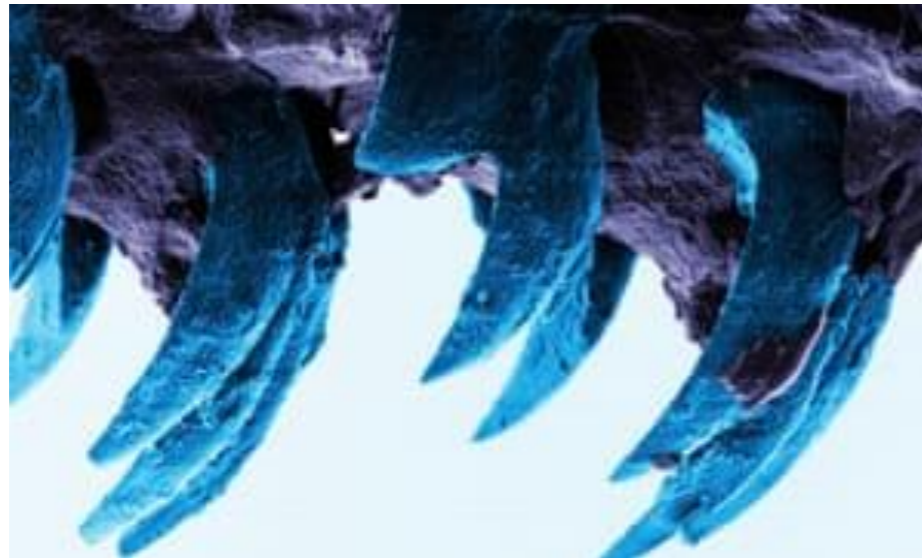

13- Limpets have a tongue or 'radula' covered in tiny teeth that scrape away at the rock surface. Photograph: University of Portsmouth



14- the GEM modular, biodegradable drone. Image sourced from: [www.washingtonpost.com/news/speaking-of-science/wp/2014/11/22](http://www.washingtonpost.com/news/speaking-of-science/wp/2014/11/22)

### CASE STUDY 4: Design for... Decompostability?

Wouldn't it be wonderful if the answers for the future were found in nature itself, as she has spent millennia coming up with successful, circular designs; it would be great if we could copy them. Examining effective designs in nature and then making structures based on these designs is known as bio-inspiration and apparently, I am a 'biophile'.

Prof Asa Barber of Portsmouth University, said: "Nature is a wonderful source of inspiration for structures that have excellent mechanical properties.... the limpet has evolved to be effective at what they do. Until now, we thought that spider silk was the strongest biological material because of its super-strength and potential applications in everything from bulletproof vests to computer electronics, but now we have discovered that limpet teeth exhibit a strength that is potentially higher. The study, published on Wednesday 6<sup>th</sup> April 2015 in the Royal Society's scientific journal *Interface* [20], found the teeth contain a hard material known as goethite, which forms in the limpet as it grows. Barber said: "We discovered that the fibres of goethite are just the right size to make up a resilient composite structure. This discovery means that the fibrous structures found in limpet teeth could be mimicked and used in high-performance engineering. Engineers are always interested in making these structures stronger to improve their performance or lighter so they use less material." [21]

Perhaps more impressive is the recent creation of 'Bio-Steel', a high-strength fibre-based material made of the recombinant spider silk-like protein extracted from the milk of transgenic goats, made by Montreal-based company Nexia Biotechnologies, and later by the Randy Lewis lab of the University of Wyoming and Utah State University (Wikipedia 1/12/19).

Mycelium is a very contemporary commodity. To solve the problem of crashed drones littering pristine, remote landscapes, a biodegradable modular drone was designed and built from the fungus (grown underground as they don't need light, which saves land space) and covered in South African mud dauber wasp spit, to waterproof it. A start-up company in New York called Ecovative Design made their first prototype in November 2014 and the organic material has applications in many product design areas- what if your product dismantled itself in landfill, just with time or with specific natural acids, to speed up the disassembly process?

#### KEY POINTS:

- 1- Nature may well have the answers to make our products more sustainable.
- 2- Could products be retrofitted with spider silk, limpet tongue and fungal parts?

[20] Barber, Asa H., Dun Lu, and Nicola M. Pugno. "Extreme strength observed in limpet teeth." *Journal of The Royal Society Interface* 12, no. 105 (2015): 20141326.

[21] [www.theguardian.com/science/2015/feb/18/limpet-teeth-strongest-natural-material](http://www.theguardian.com/science/2015/feb/18/limpet-teeth-strongest-natural-material)





### CASE STUDY 5: Pop-up fixers: OurTech

In researching local and national companies who already fix products, I was drawn to my local industrial estate in Medway, and in particular to a small office I had been recommended to get my laptop fixed once.

Our Tech ([www.ourtech.co.uk](http://www.ourtech.co.uk)) owners Mark and Chris Bell were welcoming when I contacted them and accommodating when I visited. They showed me around their business and opposite are photos I took. I interviewed them (mainly Chris) about their enterprise, where they fix 'broken' laptops and PCs and the give them back to their owners or sell them online:

Image 1: Many thanks to Chris Bell, 'disassembler' at OurTech and the team for being so open.

Image 2: Mark shows me a dusty motherboard. "They are more robust then you image" he explains in the video. "There is actually nothing wrong with this, it is just the screen... while it is out we can clean it up and update the RAM, if the customer wants, then put it back in a new shell". On the side you can see a black plastic adaptor, which cleverly lets most motherboards fit in this generic shell. Again, OurTech have hundreds of these generic cases. "It's really just the companies that want their own bespoke, specific ones with their branding on the outside" he quips. "We have a big problem with customers wanting counter warranties more than the year we offer. It is difficult for us to guarantee this (legally) but we are working on it".

Image 3: In one of a few one-minute videos I shot at this location, Chris explains to me the parts of laptops which most commonly break physically, and due to the leverage forces on them, that is usually the hinges between the screen and body of the laptop. He showed me how they retrofit these failing parts with a generic mechanism, of which they have hundreds. This saves them money and also time because they can re-fix products they have already fixed, whereas each individual company, from HP to Dell, think their designs are best and stick to them.

Image 4: One of many mobile storage boxes of shelves, on wheels, with laptop shells and motherboards. "We mostly fix PCs and laptops because there is the most profit in them. In theory" Chris boasts "we could fix anything here. We have a very good local and online suppliers and we can get the schematics easily online too, if we don't know how to put something back together. We have all the tools, but some companies make specific parts hard to buy separately... Deliberately, of course."

Apparently there is a man currently on the industrial estate who goes through all of the commercial bins finding items of technology and breaks them down for their rare metals. He brings laptops he finds in the skips and commercial waste disposal bins to OurTech, who fix what they can, then he sells them on himself. One, rare individual making a living from waste and repair, talked about like he is strange.





### CASE STUDY 6: Existing systems for end-of-life

Some European countries considered to be more sustainably advanced than the UK (i.e. our Scandinavian cousins) have massively reduced the size of landfill sites. How? They incinerate much of their waste and use it as biomass, catching the energy to boil water, turn turbines and generate electricity again. This sounds improvident but it is better than it rotting. In Sweden, for example, 50% of household waste was turned into energy and on the 19<sup>th</sup> July 2019, writes Dominic Hinde, there was 212,500 tonnes of plastic on the Swedish market, 47% being recycled, quoting from the Swedish Environmental Protection Agency [22]

On the wet morning of 12<sup>th</sup> November 2019, I went to the Hoathway Household and commercial waste site on Ambley Road in Gillingham Business Park in Kent to get a typical British angle, as change must surely start at home. I was kindly allowed in have a look around and ask questions. I interviewed Jade, who worked there, and during the course of the conversation she made some salient points:

- 1) The most troubling product thrown away was paint. Sometimes half full tins, some barely used and some brand new. These paints are full of toxins, plasticisers etc but cannot be reused or recycled and are thrown into landfill.
- 2) She has noted a marked and sustained improvement in the volume of clothes submitted and successfully passed on, to humanitarian crises or donated to 'The Jungle' in nearby Calais. (This is good because we know people learn better from mixed stories as opposed to a constant torrent of problems and issues to address).
- 3) Jade thought that by far the most binned products were kettles. She made a really good point suggesting how few were "unrecognisable, cheap Argos or Tesco own brand kettles" (for example) and said how she thought it "should be easier to track the most products which end up in skips and landfill" ... To find and fine the manufacturers?

"If we knew, by brand whose products were most landfilling, it would be easier to count who is making the poorer quality products and the company could be taxed more!"

#### KEY POINTS:

- 1- A solution to waste products must occur in an accessible, communal space which offers more than simply fixing broken products and refilling empties.
- 2- Perhaps the constant and increasing barrage by digital media that people are exposed to means they are becoming more numbed/ switched off than they used to be?
- 3- It really isn't just physical products and e-waste causing these issues, but materials such as paints and chemicals, which we give less thought to, being binned.

[22] <https://sweden.se/nature/the-swedish-recycling-revolution> (accessed 21st November, 2019)

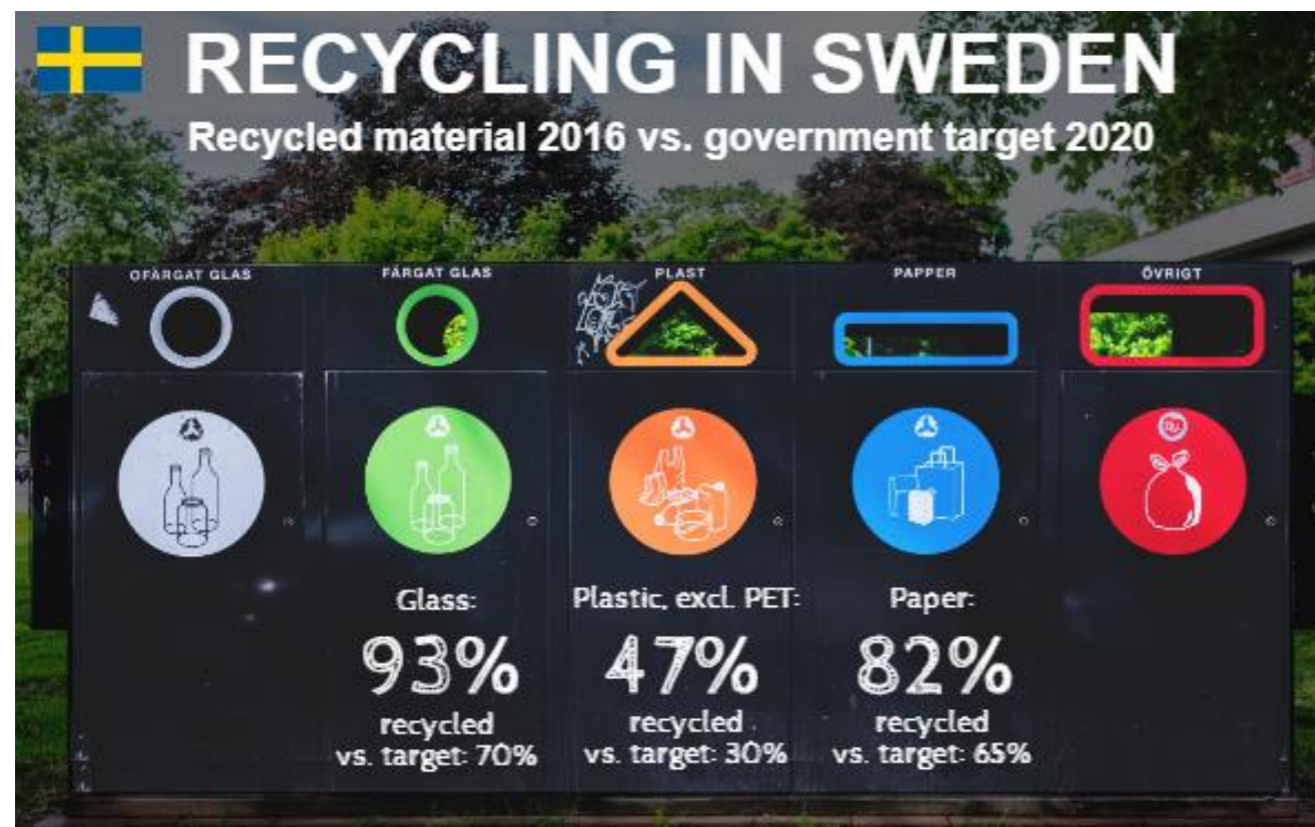

Source: Swedish EPA

Photo: Simon Paulin/Imagebank.sweden.se



15- <https://www.mcrwma.org/Calendar.aspx?EID=142>

Poor management of chemicals such as paints can cause dumps and former landfill sites to become toxic and unfit for use. While some councils do offer services to deal with this issue, it seems most end up at the local tip.



### CASE STUDY 7: BuildBrighton, the Restart Project and Repair Cafes

Poppy Mosbacher, a former Brighton University student, is a founding member of Build Brighton, a “Maker Space” in the city. Their inspirational setup is not so much about fixing broken products, but giving people a place to learn skills, create and make. A wonderful concept, put into action. Other examples of people trying to make a difference this way:

The Restart Project: <https://therestartproject.org/> lead by Ugo Vallauri, this growing international company pressure politicians & specialise in electronic products and E-waste:

<https://inews.co.uk/inews-lifestyle/homes-and-gardens/restart-project-remade-network-fixing-workshops-waste-181673>

The Repair Shop (who specialise in antiques) were recently on BBC iPlayer:

<https://www.bbc.co.uk/programmes/b081581p>

And perhaps currently the most well-known: Repair Cafes. When I got in touch with Poppy Mosbacher and explained the Re-I-Y concept, she pointed me in the direction of Repair Cafes. The nearest Repair Café to me is 20 miles down the M2 in Whitstable:

<https://repaircafe.org/en/location/whitstable-repair-cafe/>

Repair Cafés were initiated by Martine Postma. Since 2007, she has been striving for sustainability at a local level in many ways. Martine organised the very first Repair Café in Amsterdam, on October 18, 2009 and now there are nearly 1500 globally!

<https://repaircafe.org/en/about/>

On Saturday 16<sup>th</sup> November I went to investigate further. Liz Daone invited me and I met with co-founders of this Kentish branch, Bernadette and Linette, who explained the year old set up. I took the photos (opposite) and enjoyed the lovely cake, coffee and people. However, to be critical it was hard to tell if it was struggling to get going or struggling to keep going. The belief was strong and Linette repeated that “it just needs someone to connect the dots” between all these start-ups to make a movement. We talked about the possibility of setting up in Rochester and about Transition Towns: one of the first collectives in the UK for this vision. Transition Towns started in London and now there are 28 across the capital.

#### KEY POINTS:

- 1- While it is pleasing and encouraging that these places, listed above, exist, none are thriving. How many were you familiar with?
- 2- This needs to be a national or even international movement. “while flying in the face of capitalism is no mean feat, we must work to make obsolescence obsolete!”
- 3- Go and check out or even support your local Repair Café! It’s free.



*Of course, I am, like most bourgeois Brits, complicit with this problem. Much as I love to repair things (and often do as I have access to the tools and a workshop space for it, unlike many other who would like to fix their products), there are some that I still have not got around to. Do you have product like these? Am I time poor, hypocritical or both? These products are at my place of work; I know what is wrong with each of them, I know how to fix them. Each has its own obsolescence working on it and I can only promise that each will be fixed then given away or sold... and will not end up in landfill!*



16- A user easily replaces the modular camera in a 'Fair Phone', image sourced from: <https://www.ellenmacarthurfoundation.org/explore/circular-design>

## CASE STUDY 8: The 'Right to Repair'

Each country has a different approach to maintain products and sustaining levels of waste, and this right has to be agreed "high up". For the most part, this is an economic reflection. It is no coincidence that the UK, as one of the wealthiest global nations, is one of the most wasteful and inefficient. In the US, for example, only 20 states have right to repair legislation, and the legal side of it seems to, perhaps predictably, be a critical element, globally. With some shifting legal frameworks, things seem to be thankfully, finally changing.

"Household appliances will become easier to repair thanks to new standards being adopted across the EU. From 2021, firms will have to make appliances longer-lasting, and they will have to supply spare parts for machines for up to 10 years. The rules apply to lighting, washing machines, dishwashers and fridges... If British firms want to sell into Europe after Brexit they will have to follow the new rules, which apply from April 2021... Under the European Commission's new standards, manufacturers will have to make spares, such as door gaskets and thermostats, available to professional repairers. These parts will have to be accessible with commonly-available tools and without damaging the product." [23]

However, the argument is that the system will still only be minorly fixed itself, as only professionals sanctioned by companies, such as Hitachi, will be able to carry out the repairs. The goal must surely be that the consumers and owners should be able to carry out the repairs to *their* products! The manufacturers will probably counter this with points about insurances and liability.

It is estimated that the move could directly save €20bn on energy bills per year in Europe from 2030 and the current politicians are saying the UK "shall match and even exceed EU eco product regulations" as part of its commitment to reach net zero emissions by 2050. Maybe, just maybe Brexit could help us with and set a pro-eco example to the rest of the world? We can dream. It certainly would be nice if something positive came from the fiasco.

### KEY POINTS:

- 1- People are demanding their right to repair but can blame be put solely at the door of the companies providing demand to meet supply?
- 2- The economy is, itself, something which is designed and can be re-designed!
- 3- Letting companies choose who can repair is allowing them to remain protectionists.

[23] Roger Harrabin, BBC environment analyst, blogs on 1st October 2019 (accessed 27<sup>th</sup> November 2019)



**Left**  
Repair activists from around the world will convene at the global Fixfest happening in Berlin from 20-22 September

# ECONOMY

(When) Will the change come?

The Right to Repair has become the largest case study in this research as it is one of the most current and interesting issues. Poppy Mosbacher, of BuildBrighton, recommended Ugo Vallauri and his views on 'The Right to Repair'. I found issue 22 of Hackspace magazine; an extremely relevant and insightful read, so much so that most is cited below.

Vallauri is the cofounder of the previously mentioned Restart Project, and his main argument is "If you can't fix it, you don't own it", which could be taken as a mantra for this whole movement. He is making waves in political pools regarding alternatives and suggestions for the future of our products:

"... we're campaigning, with our partners across Europe, to push for a European-wide movement for right to repair. For many products there simply is no regulation whatsoever limiting the power of manufacturers to just do whatever makes the most sense to them, irrespective of the environment. For some products, some regulation exists, and we've actually pushed the option of initial minimal right to repair and repair provisions in European legislations. From 2021, new televisions, electronic screens, dishwashers, and fridges that come to the EU market will have to have a list of spare parts available for at least seven years after the product is taken out of the market, as well as access to repair professional". He is very anti companies creating the conditions for only authorised repairers performing certain types of repair and reuse of products- the believe in peoplepower.

He continues: "... this is not just in the interest of consumers; it's also in the interests of repairers of all kinds, because repairs will be faster, better, and easier. And it's also in the interests of the work done at the end of the product's life, by the recyclers: if a product is designed for disassembly, it's designed so that more of the components that still work can be removed. It's in everyone's interest. Proper regulation will mean a level playing field, so manufacturers can compete without undermining consumer rights and the environment. Until this happens, they will always try to defend the status quo... we're talking about creating an economy that makes more sense for people and the planet. To repair and reuse can be an essential part of this. No data would contradict what that it is environmentally more efficient to extend the use of the current product, rather than recuperating some materials and some components to make a brand-new product to be sold again on the market. You can also create a lot more jobs by having proper maintenance and reuse economies to prevent unnecessary recycling and throwing away of products that are already manufactured. Make use of whatever resource you already have. Keep using and making the most of the components you already have- this should be at the heart of every tinkerer. Use your amazing skills to contribute to a future where people and planet are a lot happier, by preventing waste and ensuring that everything is used to the fullest that is possible." [24]

[24] Ugo Vallauri, 'Focussing on openness in the repair economy', *HackSpace Magazine*, edition 22, September 2019. PDF downloaded 16<sup>th</sup> November 2019

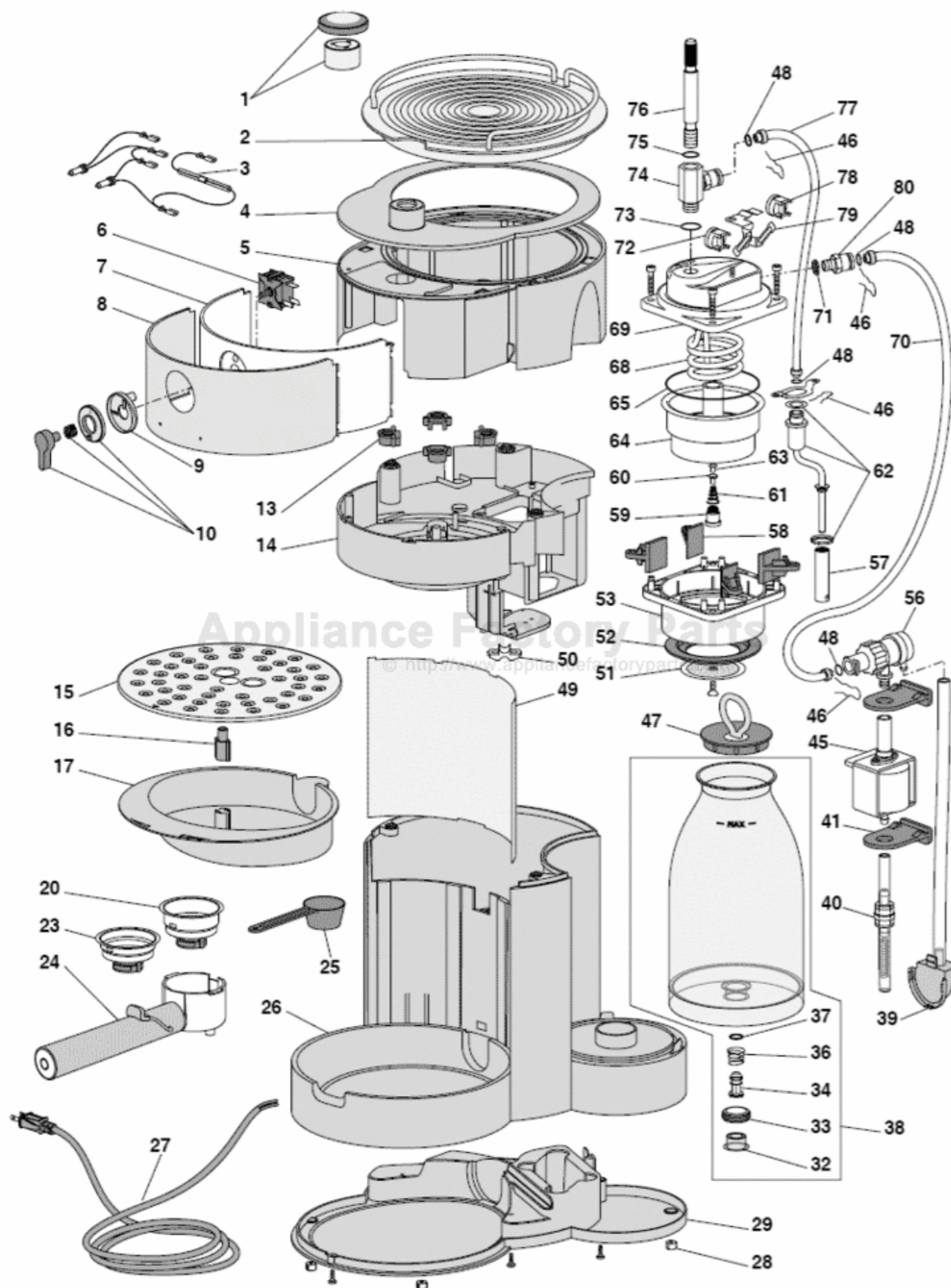

## CASE STUDY 9: Shifting Legal Frameworks

This is a/the big problem- most people don't want to fix stuff, it grows from necessity. Demand is there in the UK and supply meets it. Most are wealthy enough to buy new as opposed to fix. It needs to come from the top and effect suppliers first; demand can't lead. We are greedy: we will buy strawberries in December if they are there, without thinking or caring about where they come from. We "don't have enough time" and "schematics are scary" to many.

The image opposite shows a random product: A Delonghi ES460.S coffee maker from <https://www.appliancefactoryparts.com> which explains that 67 parts are available to fix this product, should it be broken. This site was not easy to find and finding help to fix the product, should you find the right part/tools, will be as challenging as fixing it yourself with no experience. We need help and there should be accessible places where that is available.

Under new standards being considered by the European Commission at the time of writing, manufacturers will have to make spares available to "professional repairers". These parts will have to be accessible with "commonly-available tools" without damaging the product.

Libby Peake from the UK Green alliance told BBC News on 1<sup>st</sup> October 2019: "These new standards are a massive step in the right direction and could result in nearly 50 million tonnes of CO2 emissions savings." However, in the same report, Stephane Arditi of the European Environment Bureau said: "we're missing an opportunity to make repair more affordable and readily available. Small independent repairers can make a great contribution to the economy and our society. We need to help them do their job." [25]

The counter argument from manufacturers raises questions about risk/liability, (e.g. Who is to blame if a "fixed product" shocks someone?) and making products last longer inhibits developments and discourages improvement. But would it be so bad if products lasted ten years as opposed to two? And good design would facilitate both repair and upgrading over a decade, whilst keeping 80% less waste out of landfill or strained recycle systems.

But WEEE (Waste electric & electronic equipment) often incurs the following concerns [26]:

Fluids (such as CFCs), Ammonia (in old fridges), Capacitors containing polychlorinated biphenyls (PCBs), Mercury (in some switches or back-lighting)  
 Asbestos waste (used in older appliances such as electric coffee pots, toasters and irons).  
 Lead and other substances including phosphorous pentachloride in CRTs,  
 Components containing refractory ceramic fibres (RCFs) and Components containing radioactive substances (e.g. fill level detectors, static eliminators, radium luminised dials, old trim phones) as well as smoke detectors. Government guidelines suggest all these also need to be considered in fixing and recycling old products (before they end up in the earth!)

[25] <https://www.bbc.co.uk/news/business-49884827> (accessed 18th November, 2019).

[26] <http://www.hse.gov.uk/waste/waste-electrical.htm> (accessed 21st November, 2019)



“A world of abundance, not limits. In the midst of a great deal of talk about reducing the human ecological footprint, we offer a different vision. What if humans designed products and system that celebrate an abundance of human creativity, culture, and productivity? That are so intelligent and safe, our species leaves an ecological footprint to delight in, not lament?” — Michael Braungart, Cradle to Cradle: Remaking the Way We Make Things

Image from the [ellenmacarthurfoundation.org/explore/circular-design](http://ellenmacarthurfoundation.org/explore/circular-design) (edited 26<sup>th</sup> Nov.)

These harmful chemicals listed on the previous page are merely scratching the surface of this issue. They definitely damage us on an environmental level as they seep out of our old abandoned products, even if they do make it to landfill. (Perhaps we should just incinerate them as is proving profitable in Scandinavia, but is that myopic management? The toxic fumes from high temperature incineration of biomass and landfill matter is trapped in carbon filters, which are themselves burned). Companies will say these same harmful substances are amongst the same reasons we should not be trusted or allowed to repair our technologies. The solution is simple- do not use them! This is a very complicated legal area.

However, this research is not looking at how we deal with waste, but keeping products out of landfill and away from end-of-life in the first place. The right a company has to utilize obsolescences, be they technological, dynamic or other, is equally complicated to convey, let alone challenge and change legally.

John Deere (US maker of tractors, combine harvesters, and other agricultural equipment), that allowing non-authorized repairs would be dangerous. How can we justify manufacturers making two or three years of security updates and then abandoning products? It's contributing to premature obsolescence. Why is it that Google doesn't provide ten years' worth of security updates to the phones that it provides software updates to? It has the capacity to do that, so why doesn't it? Could we think of devices with a kill switch, so the moment the smart element of the device is no longer secure, we can turn it off and use it as a non-smart device, without compromising the safety of the product?

The John Deere case is interesting because it opens up the other big issue, which is that of software. A big part of the fight for the right to repair is intellectual property. In the case of John Deere, the question was: 'can a company lock access to a product by installing a piece of software that will make it impossible for a product repaired by a third party to be used again unless it's verified again by the manufacturer?' This is a really big issue and, more broadly, extended firmware support and security updates for products is one growing cause of concern that's not yet tackled by regulation either. [27]

KEY POINTS:

- 1- Obsolescence comes in more than physical varieties, where things get thrown away because they are designed to break. Software updates are a common digital obsolescence.
- 2- This is of course all deliberate and meticulously considered, to drive a linear economy.
- 3- People want to keep their smartphones for longer and there are ways they can be designed to be disassembled easily! (See next page)

[27] <https://hackspace.raspberrypi.org/articles/campaigning-for-the-right-to-repair> (accessed 28th November 2019)



A series of dismantle-able concepts for the envisioned circular design, from the Floras CEIP report, cited opposite.

### CASE STUDY 10: A Spiral Economoy?

A Circular Design for a Circular Economy [28] is the goal. Most waste is incurred at the design stage and our views of when a product actually reaches its 'end of life' vary from country to country.

The Floras CEIP report: Designing for a Circular Economy, from the Ellen MacArthur Foundation is a gold mine for research and ideas on how mobile phones can be (re)designed for disassembly, with 8 initial concepts of disassemble able 'products' featuring opposite.

It is true of the billions of portable devices are sealed. The report goes into great depth detailing how, in their solutions, "Five of the most problematic components (display, touchpanel, CPU, memory chip, and battery) are designed for disassembly. This requires standard tools and could be done simply and fast by hand. The accelerometer remains an issue. The entire product can still not completely be disassembled. Manual disassembly is made easier nonetheless automated disassembly is not yet enhanced ". [29]

How about if we merely only every rent products and they remain in cycles dependent on your wealth? People might recoil at this notion but in truth, that is quite similar to how many already function, without knowing. You buy a phone with a 2-year guarantee, it goes wrong, you take it to a shop, trade it in. It is as though you hired it for 2 years. The trader will fix it or send it away. Millions of phones, made technologically obsolete by updates and software alone, are returned as though they are broken- they are not, they are simply sent further down the chain. This is a nice thought- your old Nokia may well still be in use in Somalia today, unless you keep all your old tech in a drawer, waiting for it to become "retro"?

Not quite a circular economy, more of a spiral as products are passed down through wealth boundaries, but still better than the all too common linear system!

#### KEY POINTS:

- 1- There are many physical ways products can be designed to be dismantled (see next page)
- 2- Products which can be dismantled can be repurposed and relocated to those who would be more grateful for them.
- 3- Don't keep old tech in your drawers, give it to developing countries. The counter argument being that, when it gets there, the less wealthy will take it to pieces for the more valuable, rarer metals within and not use it to embitter their communities.

[28] <https://www.ellenmacarthurfoundation.org/explore/circular-design>

[29] *The Floras CEIP report: Designing for a Circular Economy: Floras Poppelaars, Circular Economy Innovation Project, Schmidt-MacArthur Fellowship 2013-2014*





17- Britons throw away more than 55lbs of e-waste each year, much of which could be repurposed, if not recycled, or even better: reused. <https://www.telegraph.co.uk/science/2017/12/13/discarded-phones-computers-electronics-behind-worlds-fastest/>

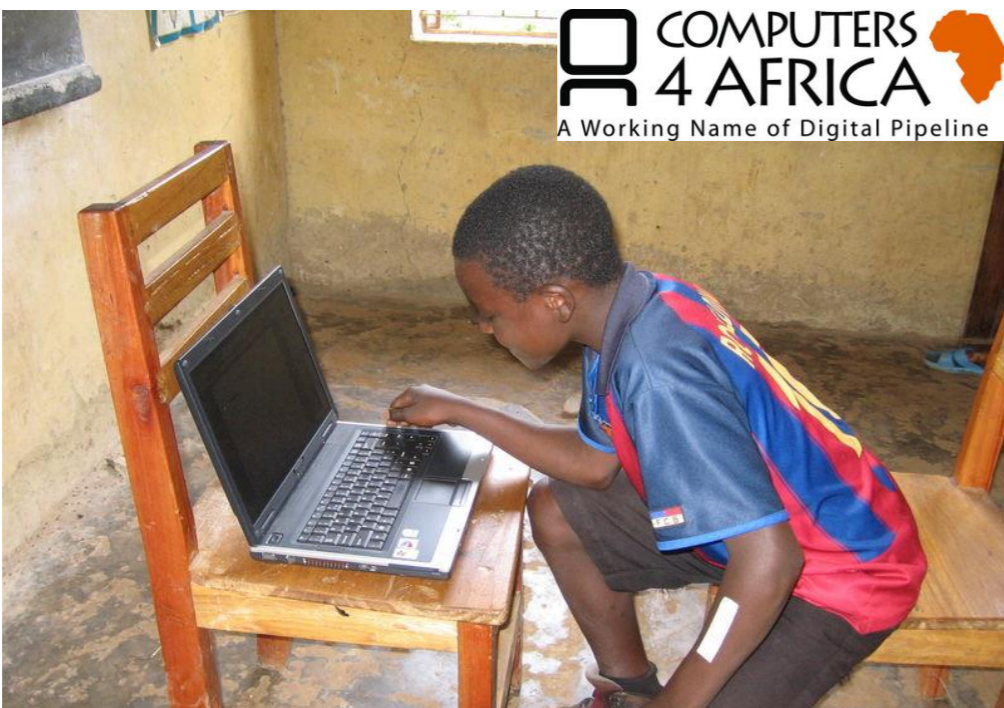

18- A boy using a repaired and reconditioned laptop, provided by Computers 4 Africa laptop in Uganda, 2017

E-waste has risen by eight per cent in two years, with just 20 per cent being recycled or reused. On average, each Briton throws away between 20 and 25kg of e-waste each year. Most of the refuse ends up in landfills, is incinerated or simply piles up unused in people's home. "... the amounts of e-waste continue to grow, while too little is recycled. "Discarded equipment, such as phones, laptops, tablets, sensors, and TVs pose considerable environmental and health risks, especially if treated inadequately. Most e-waste is not properly documented and not treated through appropriate recycling chains and methods." [30]. What some developed countries label as 'end of life' are often still of use to people who are more resourceful and less proud. Systems like this are utilized well by companies such as Computers for Africa, based just outside of Maidstone, Kent:

"Computers 4 Africa (a working title of Digital Pipeline) is a UK registered charity that supplies schools, hospitals and community projects across Africa with IT equipment that has been donated in the UK. All computers are securely data wiped (up to Ministry of Defence Standards) and refurbished prior to shipment.

Computers 4 Africa is an EAUC Strategic Partner which means we ensure they are aware of current thinking and activity in the sector and when our interests come together, we are keen to work with them for the benefit of the sector". [31]

Their primary function is reusing computers in Africa as the greenest means of IT disposal for schools/businesses/charities/individuals in the UK. They firmly believe in the principles of reuse as it is not only a simple way of being ecologically conscious but also ethical.

100% of usable donations are sent to education and community projects across Africa. If the donated items are unusable they will be dismantled for individual parts as well as being used to build new computers from scratch. The charity ensures all equipment sent out is fully refurbished, securely data wiped and have standardised operating systems and education programmes installed.

When viewed as an IT disposal service, they are not only ethically sound but also clean, green and WEEE compliant. All donations are either reused and repurposed or recycled. -If a donation is deemed unsuitable for beneficiaries, either because it no longer works or does not meet necessary criteria they will recycle all parts. Computers 4 Africa have a 0% to Landfill Policy, which means they throw nothing away.

*"Computers 4 Africa has chosen to be Carbon Neutral as it is environmentally consistent with our IT reuse principles. We believe that finding an innovative charity to support in Africa as a means of being Carbon Neutral makes the arrangement ideal. Going forward it will become increasingly important to be Carbon -Neutral and we will continue to work on reducing our footprint."* - David West, Chief Operating Officer. [27]

[30] Jakob Rhyner, Vice-Rector, United Nations University (UNU), December 2017

[31] <https://www.digitalpipeline.org/computers-4-africa> accessed 29<sup>th</sup> November 2019



### ALTERNATIVES, SUGGESTIONS & areas for further research:

When it comes to areas of further research, design for disassembly is one of the richest veins and R. Bogue, G Boothroyd and L Alting agree on the following key factors affecting e-waste: (See citation at the foot of the page for relevant sources of the tables below [32] and images opposite [33]):

Factors affecting the disassembly process	Guides to improve disassembly	
Product structure	<ul style="list-style-type: none"> <li>Create a modular design</li> <li>Minimise the component count</li> <li>Optimise component standardisation</li> <li>Minimise product variants</li> </ul>	<ul style="list-style-type: none"> <li>• Use compatible materials</li> <li>• Use recyclable materials including bonding aspects</li> <li>• Minimize material count, using the least number of different polymers</li> <li>• Minimize assembly operations</li> <li>• Design for easy separation, handling and cleaning</li> <li>• Simplify potential uses/users of products and parts</li> <li>• Use two-way snap fits/break points on snap fits</li> <li>• Provide standard, easy identification for all materials (molded-in material name or logo)</li> <li>• Identify separation or cut points</li> <li>• Use molded-in material name in multiple locations to accommodate cut points</li> <li>• Avoid secondary finishing operations such as painting, plating, coating and so forth</li> <li>• Avoid toxic materials/foams, blowing agents (CFC's), heavy metals and so forth</li> <li>• Minimize waste in production, for example by incorporating material handling programs to lower the cost of manufacturing</li> <li>• Understand side effects of processes and equipment emissions, such as paint vapor and abusive molding</li> <li>• Avoid inserts</li> </ul>
Materials	<ul style="list-style-type: none"> <li>Minimise the use of different materials</li> <li>Use recyclable materials</li> <li>Eliminate toxic or hazardous materials</li> </ul>	
Fasteners, joints and connections	<ul style="list-style-type: none"> <li>Minimise the number of joints and connections</li> <li>Make joints visible and accessible, eliminate hidden joints</li> <li>Use joints that are easy to disassemble</li> <li>Mark non-obvious joints</li> <li>Use fasteners rather than adhesives</li> </ul>	
Characteristics of components for disassembly	<ul style="list-style-type: none"> <li>Good accessibility</li> <li>Low weight</li> <li>Robust, minimise fragile parts</li> <li>Non hazardous</li> <li>Preferably unpainted</li> </ul>	
Disassembly conditions	<ul style="list-style-type: none"> <li>Design for automated disassembly</li> <li>Eliminate the need for specialised disassembly procedures</li> <li>DFD with simple and standard tools</li> </ul>	

These factors do not affect every product that can be fixed to be kept out of landfill. Tables, chairs and most items of furniture end up rotting there usually because they have minor damaged but these are of course dismantled with much greater ease, people just need tools and space to perform the task.

Types of snapfits

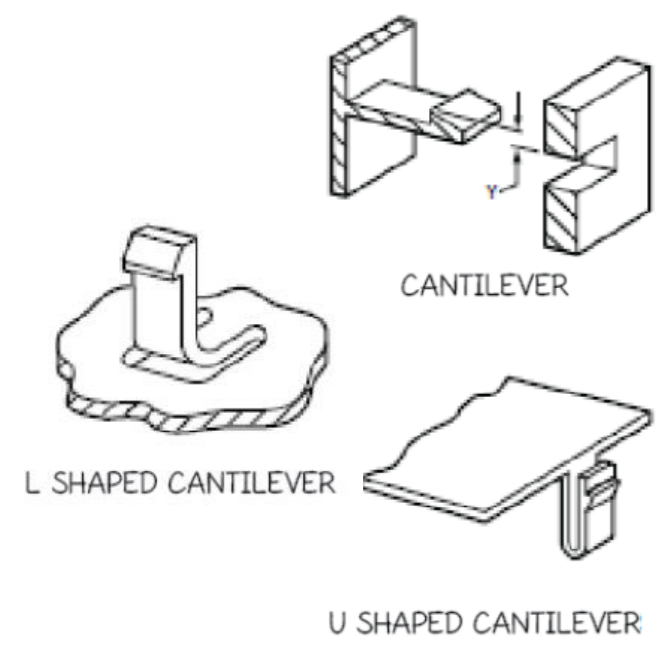

Types of disassembly

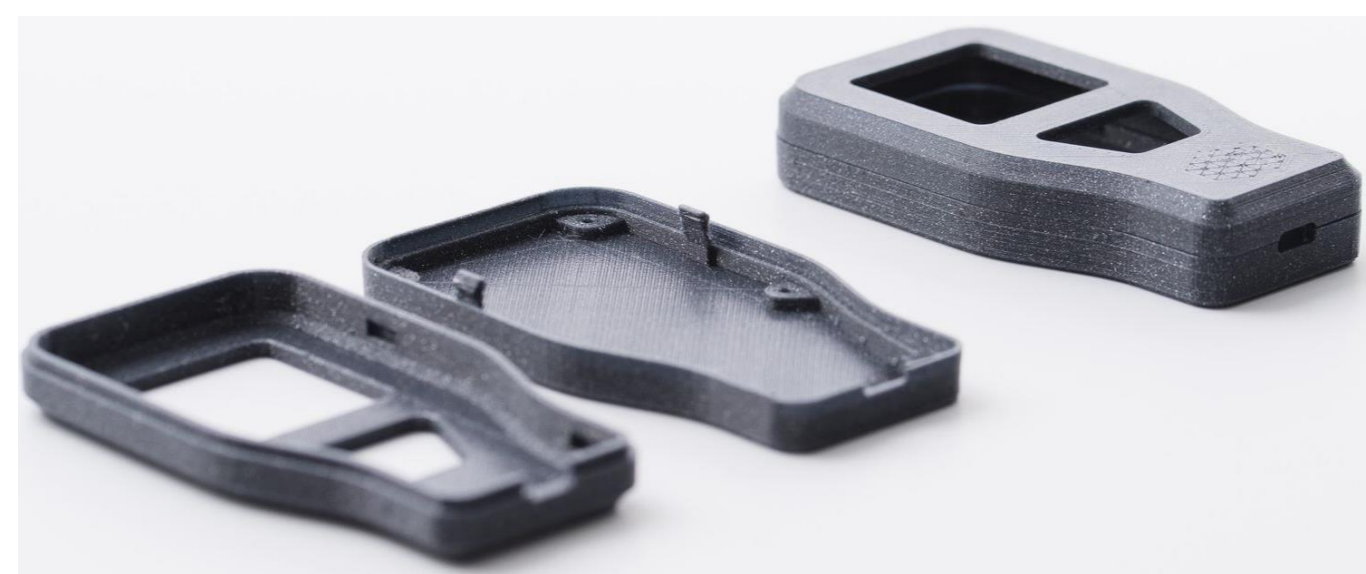
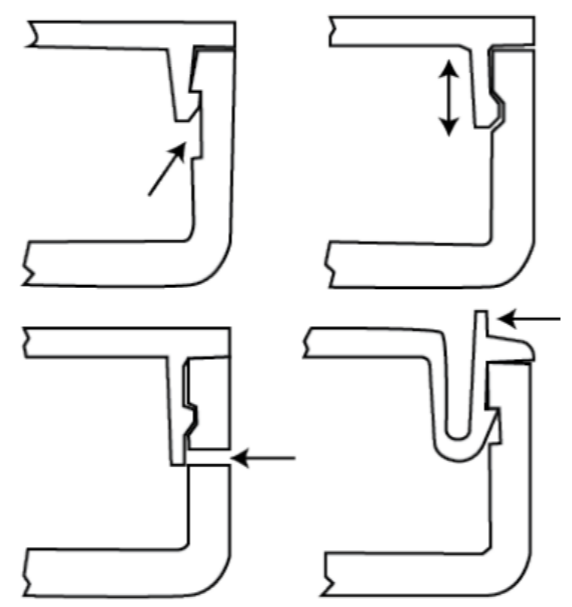

Casings for a device such as a mobile phone, which clip together using a cantilever snap-fit joint, 3D printed from recycled pulverised, plastics particles. Image sourced from: <https://www.3dhubs.com/blog/cad-modeling-3-snap-fits/> (on 30<sup>th</sup> November 2019)

[32] A. Boeijen, J. Daalhuizen, J. Zijlstra, and R. van der Schoor, *Delft Design Guide*. BIS Publisher, 2013.

[33] J. R. Duflou, B. Willems, and W. Dewulf, "Towards self-disassembling products - Design solutions for economically feasible large-scale disassembly," *Innovation Life Cycle Engineering Sustainable Development*, pp. 87-110, 2006.

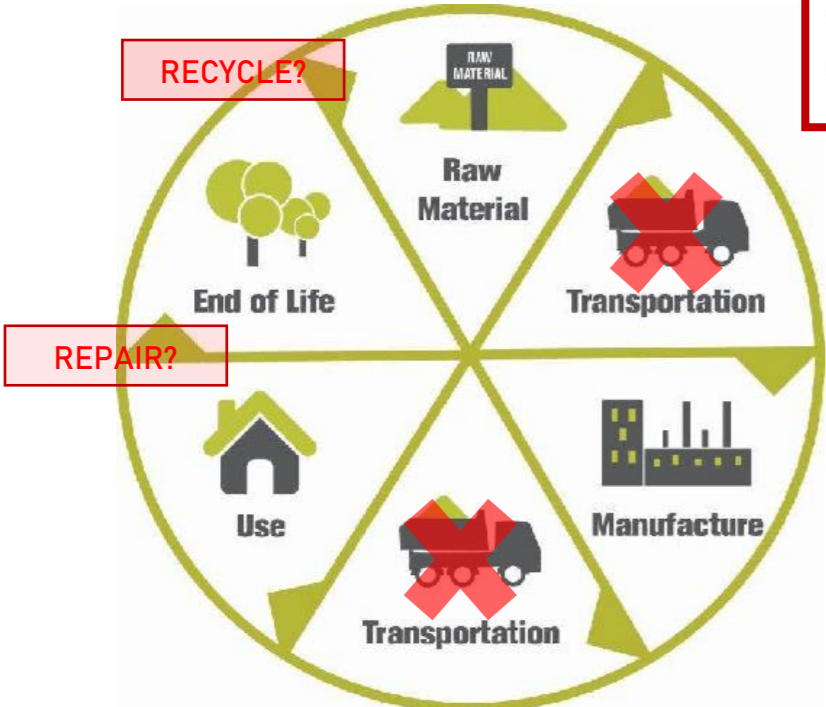
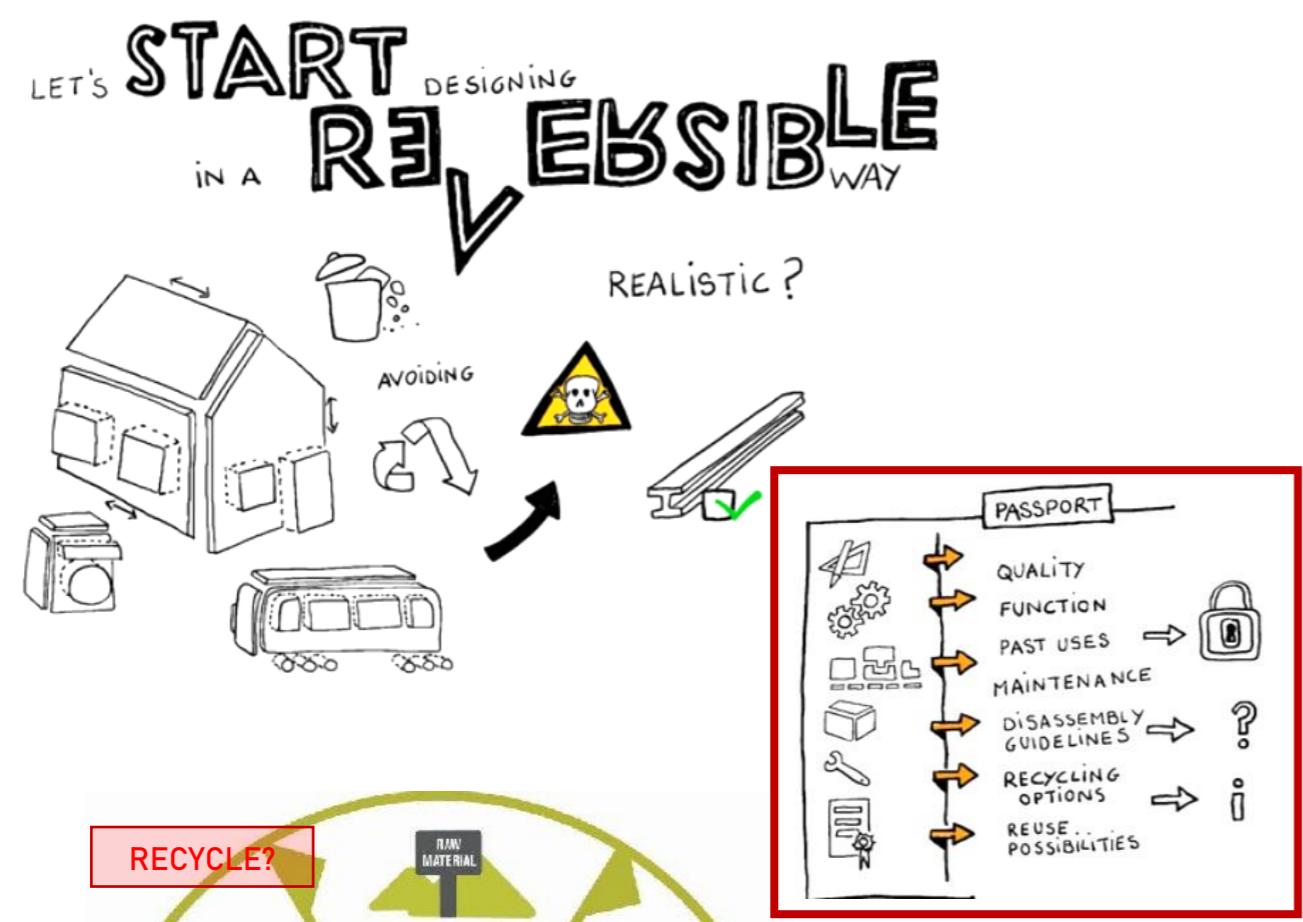

19- [https://www.researchgate.net/figure/Life-Cycle-Assessment-LCA\\_fig2\\_315762443](https://www.researchgate.net/figure/Life-Cycle-Assessment-LCA_fig2_315762443)

### ALTERNATIVES, SUGGESTIONS & areas for further research:

Fab cities and a new approach to Life Cycle Analysis/Assessment:

Fab cities (of FabLab derivation, a contemporary implication), was presented by James Toose, to students at the School of Architecture and Design at Brighton University on the 25th October 2019. Their circular economy goal is as decisive as it is impressive: In less than 35 years, Fab cities are to produce everything they consume.

There is a Cradle To Cradle (C2C) link here, as they are hosting WasteBuild this year (2019). WasteBuild is the first and only international built environment event with the dedicated ambition to eliminate global waste. Today, the construction process accounts for 40% - 50% of all materials used globally and for 20% of the waste created [34] much of this will be tackled and rectified by making the buildings, like the products inside them, dismantlable. This is a hot topic for further research: I would love to be involved in the design of architecture for disassembly- a topic brought to my attention by Duncan Baker-Brown.

In a Fab city, buildings are seen as material banks. Modular components produced locally, sourced from the city (with only data passing regionally or internationally) which can be repaired, replaced or recycled back into the system. The number of cycles a material or part has been through is kept in its 'passport'. The image to the left, sourced from a YouTube video found when following the cited link below, explains the concept well.

When big buildings down to small products reach the end of life in a Fab city, it is either dismantled (and repaired if necessary) and sent onto it's next cycle of use, challenging and rethinking the Life Cycle Analysis (LCA) of products:  
Raw materials- make sure they are near to the city's manufacture- use materials which are relevant to that particular city, do not import and eliminate the need for transport.  
Manufacture- make sure products are made in the cities where they are intended to be used. Maximise the potential for a product to be repaired when it can no longer be used.  
End of life- Only when the product cannot be repaired or reused by someone else, consider recycling its base materials.

#### KEY POINTS:

- 1- One of the main ambitions of this research is to suggest and explain how products should be treated exactly the same as buildings in Fab cities, just on a smaller scale.
- 2- Repair centres will be a fundamental part of keeping the economies of Fab cities circular.

[34] *WasteBuild, an international event for architects, engineers, clients and developers. Central themes are: "Cradle to Cradle, dismantling and circular economy"* <https://www.c2ccertified.org/events/wastebuild-2019>, (accessed 27th November 2019)



### ALTERNATIVES, SUGGESTIONS & areas for further research:

Re-I-Y: Repair It Yourself. An idea, a potential movement. Inspired by the research and case studies above, it can be best described as Repair Cafés which travel to where they are needed most. It is a rough concept and needs a lot of work and further exploration, but imagine:

Workshops equipped with all the iFixIt kits, Instructables technology, a registered electrician, access to all online schematics and guides and the space to get people fixing, up cycling, improving. It could travel from town to town, school to school, or even prison to prison:

On the 19<sup>th</sup> November 2019, Justice Secretary Robert Buckland said new Conservative policy would tackle "genuine concern" about sentencing. In an interview with Radio5 Live he explained: "The goal is to double the number of those in employment six weeks after their release, with measures including a 'prison education service' to oversee learning across all jails, more workshops to employ prisoners during their sentences, and a dedicated work coach in every prison to link inmates with job centres ahead of their release."

What better than educating them how to fix old products and giving them a chance to contribute to a society with the Right to Repair in the coming years- an army to help in the circular economy of the coming years.

Add to this army jobseekers, retirees or older people looking for hobbies or anyone with spare time- keep the Repair Café concept- the social theme must be at the core of Re-I-Y; as much as educating people, it should be about bringing them together to share ideas.

Take Re-I-Y to universities, colleges and schools. As a teacher, I know how much the latter are crying out to diversify their curriculum, bringing 'real world skills' to the fore. Year 10 and year 11 pupils have 2 hours of 'enrichment' at my school every Friday and this is a popular theme across many schools: pupils learn to make tea, put up shelves, change plugs, use and iron etc. Re-I-Y could integrate perfectly with this and the D&T/computing technology syllabi.

Less academic but practical boys and girls could train for apprenticeships as fixers and maintainers of products, goods and e-waste, providing the current legal frameworks shift as we are suggested they will.

#### KEY POINTS:

- 1- Re-I-Y: A travelling workshop to fix and improve tired or broken products, is a concept distilled from this research project
- 2- Re-using old shipping containers to make these mobile, social, educational and anti-landfill stations would be perfect.
- 3- Re-I-Y is not like other project as its focus will be mobile and wider (see CAD model)

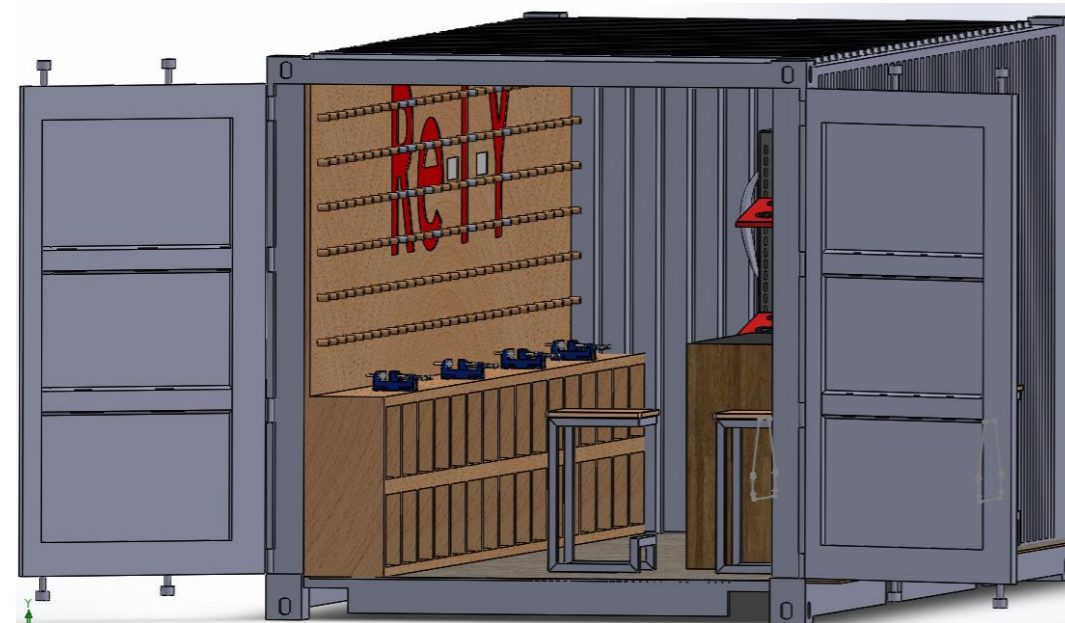

20- A CAD model of a possible mobile Re-I-Y unit in a 2400mm x 6100mm shipping containers, created on Solidworks



21- Pupils at a school in Kent have lessons once a week where they learn to maintain

### ALTERNATIVES, SUGGESTIONS & areas for further research:

Education is everything; learning about issues is key to changing them. Let's make this officially part of the syllabus. Of course, this is already happening- few suggestions in this research have been purely original and new. At several schools in Kent they now offer repair training as part of the (C)PSHEE 'enrichment curriculum'. In these lessons (photographed at King's School Rochester on a November Friday afternoon) pupils are taught how to iron shirts, repair certain products, make a cup of tea, use a needle and thread to sew buttons back on, change fuses in plugs etc,

"Most waste problems facing their generation have been created over the previous 70 years. We live in a time of transition to a more digital world, where automation, sensors and artificial intelligence are transforming all the industries, our daily lives and our societies [35].

The rise in waste has been driven by falling prices in electrical devices, coupled with companies encouraging customers to buy the latest version of their model at smaller intervals, and making old devices incompatible with new software. Teaching the next generation how to counter and tackle this gives the demand a chance to change the supply.

It would be easy to argue that absolutely every pupil would and should benefit from this kind of training. Mobile Re-I-Y stations could offer this, both educating and raising awareness to problems future generations are going to face, as "experts foresee a further increase in e-waste of 17 per cent is predicted by 2121, with the amount of annual waste increasing globally to 51 million tons a year as the digital world continues to expand. Close to half the world's population, 45.9 per cent, now use the Internet, up from 20.5 per cent in 2007. Some 48 per cent of households have a computer, up from 30.2 per cent in 2007. "E-waste management is an urgent issue in today's digitally dependent world, where use of electronic devices is ever increasing," [35]

With a degree in product design, and after 12 years of teaching Design and Technology in secondary schools in Kent, I know this could be a meaningful project and potential great success. Issues it would face are the start-up, who to contact, and a general resistance in schools to sacrifice school day time to fit in with their current curriculums, especially as it would be pitched at years 10-13 (GCSE to A level students).

#### KEY POINTS:

- 1- Bring fixing in as part of PSHE (Personal, Social and Health Education) to UK schools.
- 2- Get the next generation learning how to fix 'their' products

[35] Houlin Zhao, Secretary-General of the International Telecommunication Union, December 2017.



22 - <https://www.mrbox.co.uk/container-gallery/opensider-container/>



Re-I-Y containers trundle into town to fix to assist and train residents young to old how to maintain their products, in a heavily photoshopped image provided by <https://www.alamy.com/stock-photos>

## ALTERNATIVES, SUGGESTIONS & areas for further research:

Re-I-Y: a concept for a communal improvement space. It could come to you, to improve your products, improve your community, improve your carbon footprint.

Just as there should, and hopefully will be more design for disassembly in our modern architecture, so should there be more Repair shops.

Just as there should, and hopefully will be many more bicycles or electric scooters on the streets of major UK cities, like Lisbon and other leading European cities, so too should there be more Restart Projects.

Just as there should be more humane, pro-rehabilitation and welfare prisons in the UK, so there should be more Repair Cafes. They aren't seen as cool or essential, yet, but then neither were vegetarianism and veganism in the 70s & 80s, only recently are people getting on board.

Re-I-Y is a proposal for a combination of all the best parts of the above incentives and more. It should be a place to get stuff fixed. Not just electronics but furniture too. Big to small- get your dishwasher fixed and up-cycle your bedside table. Don't buy new stuff, adapt your old furniture when it does not fit. Learn: Put the years of Lego to use. Re-I-Y should have a space where children's curiosity as to how stuff works can be rewarded, where they can take things to pieces while their parents can feel empowered to keep a product going even though the warranty has passed.

Go to Re-I-Y to get your cartridges, glue sticks or pens refilled (or it comes to you?)

Go there to take paints and chemicals you are not going to use, or go there get a cheap change of paint as opposed to buying a whole, new big tin. Up-cycle furniture instead of discarding it.

More than that, if Re-I-Y spots can find permanent homes, they should not just be a place to fix stuff. It should also be a place to get a coffee, meet people, take the kids, have classes. It would be a pro-communal space, with retirees teaching the less knowledgeable how to maintain and sustain.

It would be wonderful if the very building chosen for a local Re-I-Y to be located in could itself be repaired or rejuvenated by the project, but reclaimed shipping containers could do, meaning Re-I-Y could travel from town to town and around the UK to where they are needed most.

### KEY POINTS:

- 1- Re-I-Y is a memorably named incentive for a local or mobile scheme to popularise repair.
- 2- A place to maintain new, repair old and trade and parts components. While it's in your town it could challenge boot fairs and replace people's thoughts of freecycling or Ebayng old/broken things .



23-Canon dSLR exploded view. Courtesy of www.PhotoNLab.com

### ALTERNATIVES, SUGGESTIONS & areas for further research:

According to a 2014 report, around the world we generate around 41 million tonnes of e-waste each year. That's the equivalent of throwing out 800 laptops every single second. In the UK, households and companies are responsible for throwing out around two million tonnes of WEEE each year [36],

The highest carbon footprint parts of phones and laptops should be the parts most easy to remove and recycle or replace, though this isn't the current methodology, globally or locally. Even complex products, such as the camera opposite, can be broken down, though not easily. We know part 7 is the most replaceable as lenses are designed to be changed. The majority of eco-harm and value is in parts labelled 1 to 4. Mechanisms in 5 and 6 can be repaired and replaced.

You will not convince companies to sell fewer units. This incentive will not come from their end. Apparently, it must come from the consumer. If they are not going to manufacture more durable products due to less return of investment, make them! Reward empathetic design. Zippo, for example, offer free warranty and repairs for life. Why does this sound so outlandish and yet now the sales of good act covers a mere 12 months? Is it more outlandish than fining people for the waste they produce?

Re- I - Y the concept should be Free-I-Y in every town, but it depends on local councils and government, who should fund this but are maybe bed buddies with big business? Re-I-Y collections of white goods could run in tandem with council/government directed pickups and drop offs. Re-I-Y could be a physical space to exchange products and parts instead of taking them to the tip. Up-cycling and shabby chic is in. People would be proud to sport their repaired phone, knowing that they were doing their bit. If fixed products were tagged or sprayed green, for example, they would become a 'status of cool', a symbol for the left-wing subversives, undermining the capitalistic systems. This could be the start of the Tech Vegans, taking back their products.

#### KEY POINTS:

- 1- The time has come! The Tech Vegans® are on the rise! Be proud of your repaired phone.
- 2- Provide a space for people to share materials, technology, expertise and handiness.
- 3- Students, retirees, maybe even inmates could learn skills and repair products.



24- Photoshopped Alamy stock photo



25- <https://www.flickr.com/photos/toasty/31917947123>

[36]- <http://i.unu.edu/media/ias.unu.edu-en/news/7916/Global-E-waste-Monitor-2014-small.pdf> (downloaded 27<sup>th</sup> November 2019)



## CRITICAL CONCLUSIONS:

There is no doubt in my mind that this could and should happen, and not just in the “developing countries” where people are ‘time rich and currency poor’ enough to take products to pieces, for their raw material value. It could and should get significant council and governmental funding too here. It is difficult to look beyond even the South East of the UK at these preliminary stages of research. However, research has led to conclusions of significant drawbacks we could face trying to implicate such models, namely: space, time and resources.

How do you promote this and ensure it is successful, especially as it seems it must not fail? The response from BuildBrighton, whose blog has not been active since 2017, was not encouraging:

“... We've considered doing repair shop stuff but currently we do not have any activities in that area mainly due to concerns about how feasible it is to resource activities (i.e. to get members to help - participation isn't very high in the club right now) and also such things as insurance and liability...” Samuel Longbear, BuildBrighton.. This, sadly, appears to be a theme. Repair Cafes are also struggling with attendances and homogenous attendees.

Where could this happen?

Space is a premium. Previous suggestions of warehouses, schools, town halls and even prisons are probably naive. This would be one of the big barriers such a project would face.

Red tape will (always) be an issue. For example, you would need to hire a certified PAT tester and it is difficult to know where we would stand in terms of insurance and liability. Even the Repair Cafes needed to pay their qualified electrician. All other members present were volunteers. The first Re-I-Y would need to benefit from legal advice beyond the realms of this current level of research. Easyfundraising so far has raised £27000000+ in its early years by simply adding suggestions to the end of online purchases with Amazon, Argos, John Lewis and Ebay, Freecycle etc. but how on board will such companies be with the new ‘Right to Repair’ movement? It should target Cradle to Cradle funding and certification!

On the 24<sup>th</sup> October, Emma Collins gave a presentation at Brighton School of Architecture and Design, where she explained how we can create and develop online communities. A research at the university, she showed her practical approach and the power of communicating through visual narratives, such as ‘5-minute crafts’ on YouTube. Experience like hers would be key to get an approach like Re-I-Y trending.

### KEY POINTS:

- 1- If it is all just supply and demand, then supply products which are dismantlable
- 2- Demand more places (online?) where this happens, safely, with the correct equipment.
- 3- If Brexit is to make Britain better than Europe, use causes like this to prove it!



26- <https://brilliantmaps.com/europe-at-night/>



Established in 2010 by William McDonough and Dr. Michael Braungart, Cradle to Cradle Certification is a globally recognized measure of safer, more sustainable products made for the circular economy. These are a key flagship company a start-up like Re-I-Y should look to.



## HOUSE RULES



- The work carried out in the Repair Cafe is performed free of charge on a voluntary basis by the repair experts at hand.
- Visitors carry out the repairs themselves where possible but repair experts on site can help out if required.
- A voluntary donation is greatly appreciated to allow the Repair Cafe to continue running.
- It is imperative that visitors stay with their items when they are visiting the Repair Cafe, volunteers and Repair Cafe organisers cannot be held accountable if items are lost after being left.
- Repair experts are entitled to refuse to repair certain objects.
- Neither the organisers of the Repair Cafe nor the repair experts are liable for any loss that may result from advice or instructions concerning repairs, for the loss of any items handed over for repair, for consequential loss or for any other kind of loss resulting from work performed at the Repair Cafe.
- Any use of new materials such as leads, plugs, fuses or applications will be paid for separately.
- Repair experts are not obliged to re-assemble disassembled appliances that cannot be repaired.
- Visitors offering broken items for repair do so at their own risk
- Visitors to the Repair Cafe are solely responsible for the tidy removal of objects that could not be repaired
- To avoid long waiting times a maximum of one item per person will be examined. The visitor will rejoin the back of the queue should they have another item to be repaired.

**Please sign to confirm you have read, understand and agree to abide by the Repair Cafe house rules:**

## CRITICAL CONCLUSIONS:

Like it or not, planned obsolescence is imbued in our culture and economy and it would take something massive to shift this paradigm. This research sadly does not (yet) contain that 'light bulb moment' but, going back to the first light bulbs, the Phoebus cartel were the first to be designed to last 1000s hours and their makers were fined if they went over! This, it could be argued, is where it started and is a clue how it could be reigned back in. The next famous example was a mere 50 years ago in the 60s, nylon stockings are designed to fail too (nylon is actually extremely strong and had previously been developed to make parachutes) then followed dynamic obsolescence designed by Alfred P Sloane and his team at Ford, considered to be the first example of dynamic obsolescence. The point is, if so much effort is going to go into designing a product to become outdated or fail, equal effort and thought should go into how they can be fixed or be of use in their 'next life', and if they fall short the designers and manufacturers should be fined, opposite to Phoebus cartel 100 years ago. And if you say that is too idealistic and not economical then it begs the questions- Where does it end and who is accountable?

Re-I-Y should be mobile, with a section, van or truck for furniture, a section for trade, a section for materials and paints and a section for e-waste repair or exchange in shipping crates on trucks, or simply in the back of branded lorries, travelling from town to town, school to school, prison to prison as mentioned, giving inmates useful tasks and real world skills, spreading the word. Perhaps this is how Re-I-Y could start, if it cannot find suitable permanent locations.

Places such as BuildBrighton and Repair Cafe could be described as failing, due to lack of funding and lack of branding. People don't know they exist- greater advertisement is needed. Other companies could do very well to get on board with this repair and fix movement, such as Lego and Mechano. They could endorse events and workshops. Freebay, Freecycle and Facebook advertising more social spaces, such as: "This coming Sunday at King's School Rochester- 'bring your broken' and learn how to fix and save!" As co-founder of my school's sustainability department, I have already broached this.

### KEY POINTS:

- 1- Sustaining your world and way of life shouldn't cost the earth.
- 2- Re-I-Y could be mobile, with departments for each specialty based in different Lorries.
- 3- funding would be key and, with refinement, this research could be pitched to Lego or (Fre)Ebay. Facebook needs a positive public image makeover...



27- A company called Mr-Box already specialise in converting old shipping containers into mobile workshops. Image sourced from: [www.mrbox.co.uk/container-gallery/opensided-containerised-workshops/](http://www.mrbox.co.uk/container-gallery/opensided-containerised-workshops/)

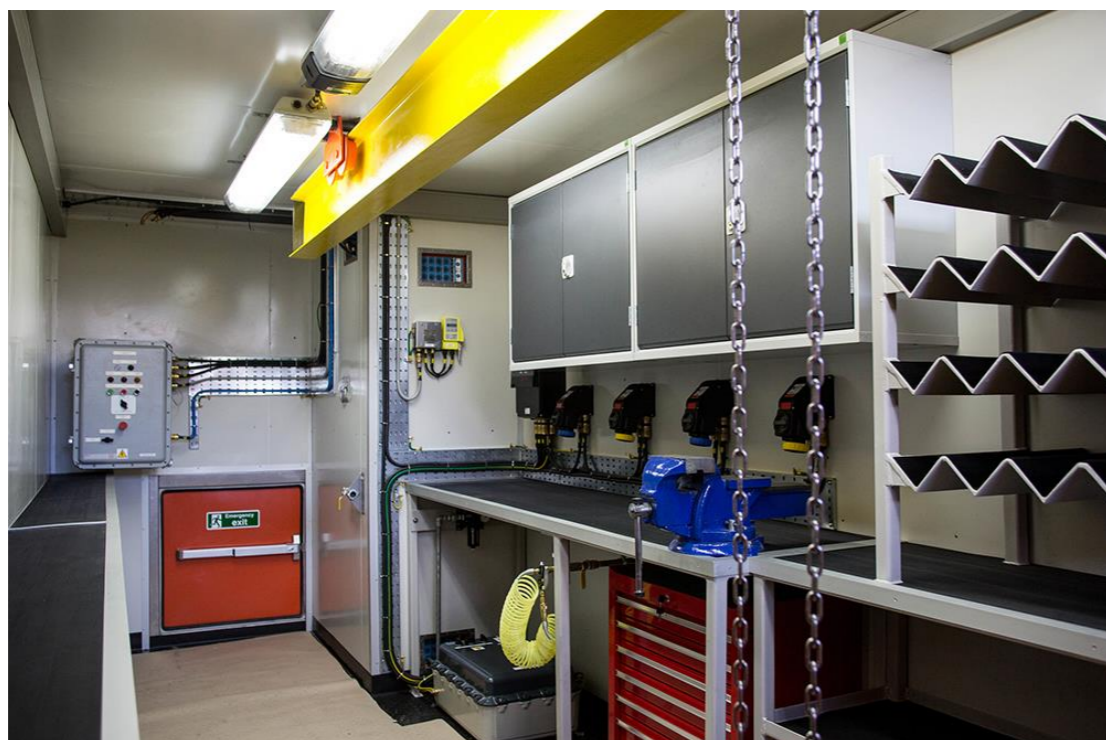

28- On 1st August 2019, OEG Offshore delivered £500,000 of equipped workshop solutions to the Coral South Project in Mozambique ([www.oegoffshore.com/news/](http://www.oegoffshore.com/news/))

### CRITICAL CONCLUSIONS:

It is easy and popular to criticise consumerism and the capitalist system, especially in these uncertain political times. While it does seem flawed, I can only suggest idealistic, carbon-based alternatives. Yes, the economy itself could be redesigned, but not by this research.

Money does indeed currently make the world go around and it works to some extent. It is easy to argue that it works much better for some, than others, and maybe the old Cree Indian proverb will come true:

"Only when the last tree is cut down, the last fish eaten the last stream poisoned will we realise that we can't eat money."

WHAT? Re-I-Y setups would offer people a place to go to fix electrical appliances, furniture and refill products (ink cartridges to board markers etc.) at prices comparable to buying new. They would also offer young-old members of communities opportunities, apprenticeships and classes to learn how to maintain their products and sustain their lifestyles without buying new. Re-I-Y should go to them, around the UK, probably by road but ideally by train or boat.

WHERE? Re-I-Y setups would need space. In summer, perhaps arrangements could be made with schools. During term time warehouse space would be hard to come by, especially nearer community hearts in town centres. A university with a workshop would be an ideal location (if you are reading, Big Build Brighton). Therefore, as mentioned, perhaps the best solution would be if Re-I-Y were mobile.

WHO? If visiting a school or university, teachers and students of the establishment could volunteer or support for pay, depending on funds available. Another solution could be to make the most of a burgeoning, aging and retired population, who have tons of experience, particularly with fixing things, and perhaps a bit more time than those currently employed. Jobseekers might be interested and, previously floated, was the concept of inmates using their free time to fix and make a positive contribution to a community.

HOW? This needs a well-considered combination of space-sourcing, branding and advertisement (to raise awareness) involvement from councils on a regional scale and governmental on a national level, as well as funding from parallel companies who would want to be associated, uniting Repair Cafes, Transition Towns etc who already exist.

WHY? Because if we don't explore and act on ideas to address out wanton wastefulness, we will continue to waste resources, scar and trash our countryside and ultimately poison the planet. Caring for our earth is our responsibility and all big changes start with small steps.

How about WHEN? When are more businesses going to stand up and say we are not going to sell this cheap rubbish only for it to become even more rubbish is a matter of months? When are more people going to choose not to disposable junk? Any why does it have to be the people- why do they have to choose? Why are they allowed to buy it, why is it allowed to be sold? Why does the responsibility have to come down to us, to check it is sustainable? We should be able to trust the companies making millions out of us.



29- <https://www.ideas4allinnovation.com/innovators/iceberg-talent-innovation-hr/>

## CRITICAL CONCLUSIONS:

"We live in a time of transition to a more digital world, where automation, sensors and artificial intelligence are transforming all the industries, our daily lives and our societies," said Antonis Mavropoulos, President of the International Solid Waste Association who helped UN academics compile the report.

"E-waste is the most emblematic by-product of this transition and everything shows that it will continue to grow at unprecedented rates. The average smartphone life cycle in Britain is now under two years and there are more mobile phone subscriptions and handsets (7.7 billion) globally than there are people on Earth (7.4 billion)". [37]

It's a people problem, but we have been encouraged to be this way. If change is to come it will have to be incremental, but the cold reality is that it's probably already too late to design products to just be repairable, though of course it helps. It may be too late to start manufacturing products which are merely carbon neutral, as many are coming to the sad conclusion our current climate emergency may well have passed the tipping point.

Products of the future need to not only utilize the right to repair and empower the customer, but they also need to be designed to be carbon negative.

Due to their size it is easier to make buildings carbon negative. Though a terrific amount is outlaid in their manufacture, clever design means that over their life and use, buildings of the future should act as material banks and carbon sponges.

This research is product centric however, and weaving carbon negative technologies into modular or disassembling products of the future is trickier. There are some insights into technologies which are sure to receive heavy investment and hopefully be on the rise. This will be the next step for this research, but for now I have run out of time, (as might we all):

Upcoming research into carbon negative furniture:

<https://www.anthropocenemagazine.org/2016/10/carbon-negative-furniture/>

Products being designed to act as carbon dioxide dumps in the future:

<https://www.greenbiz.com/article/5-surprising-products-companies-are-making-carbon-dioxide>

---

[37]- Sarah Knapton, science editor for the Daily Telegraph, 13 December 2017, accessed 29<sup>th</sup> November 2019.



#### THANKS TO:

Whitstable Repair Café (specifically Liz Daone for her time).

Hoathway Household and commercial waste site, Gillingham Business Park, Kent.

BuildBrighton (esp. Polly Mosbacher and Samuel Longbear for their advice).

Mark and Chris Bell and the gang at OurTech, Rochester Industrial Estate, Kent.

#### FILM BIBLIOGRAPHY:

Generated with Sony Vegas Pro

Thanks to Russel McVeigh (editor)

and Matthew Freedom for access to his VideoBlock account for moving images